

Complete catalogue 2012

- ▶ Contour
- ▶ Roughness
- ▶ Roundness
- ▶ Stylus tips
- ▶ Accessories

optacom

Measurement technology - Made in Germany

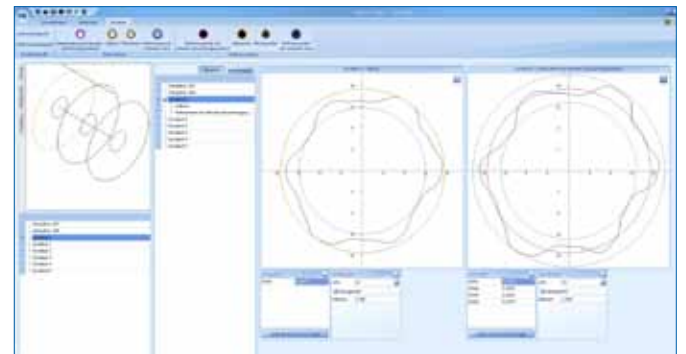
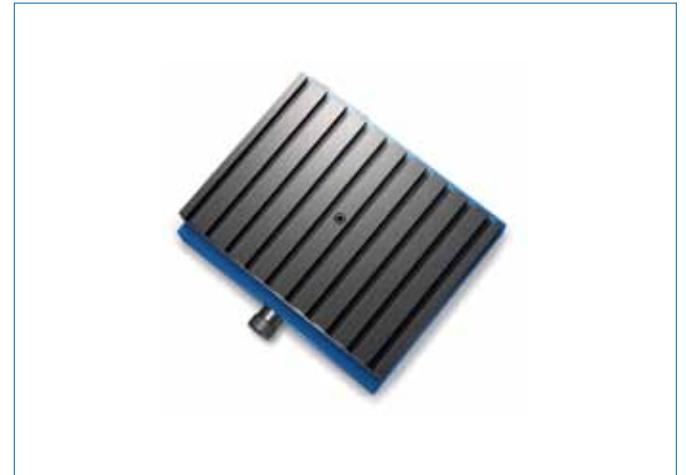
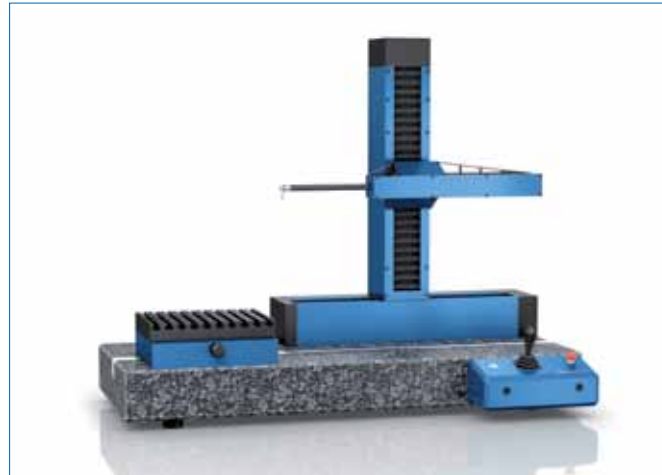



optacom product range overview	2
Content	3
optacom measurement technology	4
The advantages of optacom measuring systems	5
optacom VC-10	6
optacom LC-10	8
optacom Y-tables	10
optacom vises	11
optacom topdown	12
optacom rotary-swivel table RSY 240-25	13
optacom stylus tips	14
optacom special solutions	17
optacom contour	18
optacom rough	24
optacom round	26
optacom OIS	28
The best for last	31

Your investment in optacom is protected for years to come thanks to:

- ▶ **Lifetime free software updates**
- ▶ **Modular expansion of our machines**
- ▶ **Subsequent expansion via options**
- ▶ **Certification according to DIN EN ISO 9001:2008**

Made in Germany

optacom develops, manufactures and distributes world-class surface measurement systems since its founding in 1999. These measurement systems allow evaluation of contour, roughness, and roundness in a single-pass. A foolproof, fully automatic and extremely rapid calibration as well as an equally rapid, uncomplicated stylus tip replacement constitute the hallmarks of carefully crafted precision systems.

Thanks to a broad range of special tracing arms and machine options, e.g., the newly developed rotary-swivel table, even composite or other complicated measuring tasks on complex parts become almost child's play. Our products have convinced numerous manufacturing and measurement laboratories worldwide of the quality, robustness and efficiency of our measurement systems.

optacom's young and enthusiastic team takes care of all customer concerns. The emphasized partnership with the customer ensures the rapid realization of individual needs and special measurement requirements. Anyone who has ever worked with an optacom system is reluctant to change. "Follow-up orders are fortunately very common in our daily business. And also the friendly confirmation of our customers that shows we are on the right track with our concept," says founder and CEO Diana Erhard. Now, let us show you and win you over.

Innovations made by optacom





The advantages of our mechanics

- ▶ Additional options may be added at any time
- ▶ Lowest follow-up costs
- ▶ Nearly wear-free parts
- ▶ All measurement systems are incremental, optical, and contactless
- ▶ Very low consumption of stylus tips thanks to optacom soft-touch
- ▶ Stylus tip breakage is almost impossible
- ▶ The machine protects stylus tips and tracing arms via collision-detect feature
- ▶ All machines measure as you manufacture without stylus arm-pivot
- ▶ Our guides have a maintenance interval of 50 km
- ▶ Measuring range up to 425 x 425 mm are standard
- ▶ Simple machine operation via built-in joystick
- ▶ The movement range and the measuring range are identical for all our machines

The advantages of our software

- ▶ Single software interface for all modules
- ▶ Intuitive software solution, resulting in low training requirements
- ▶ Software is multi-language and allows customization
- ▶ Contour, roughness and roundness evaluation is possible in one single evaluation
- ▶ Free software updates
- ▶ Clearly arranged element list with red-green evaluation
- ▶ Fully automatic calibration of the stylus tips
- ▶ Red-green evaluation using a percentage tolerance display
- ▶ Automated export to Q-DAS
- ▶ Redesigned print manager for meaningful and conclusive reporting
- ▶ Evaluation and print views are saved separately
- ▶ Industrial PC with a modular plug-in card design
- ▶ Integrated online diagnostic tool



Are you looking for an all-round system to control the whole variety of contour measurement tasks with outstanding accuracy? If so, the optacom VC-10 may be the right solution for you. It performs contour measurements alone or in combination with roughness simultaneously as well as roundness measurements or composite measurements (e.g., with the new rotary-swivel table).

Thus, even complicated measurement tasks of complex formed objects will be easy to handle. The VC-10-EL/-UL was specifically designed for extension with our rotary-swivel table. Through the extension of the measuring range in X and Z axis up to 200 mm, we can fully leverage the possibilities of the rotary-swivel table.

Therefore, the VC-10 is a convincing value proposition because of its ease-to-use nature and outstanding precision. At the stylus tip it reaches a genuine - not just simply calculated - resolution of 3 nm over the entire measuring range.

Technical data

Resolution in X and Z axis:	0.002 µm
Resolution at stylus tip:	0.003 µm
VC-10 measuring range horizontal/vertical (X axis /Z axis):	225 mm
VC-10-EL measuring range horizontal/vertical (X axis/Z axis):	325 mm
VC-10-UL measuring range horizontal/vertical (X axis /Z axis):	425 mm
Measurement system:	optical incremental and contactless in all axis (X, Z, T)
Precision:	+/- (0.5 + L/100) µm
Maximum measuring force:	10 - 150 mN
Measuring speed:	0.1 – 2 mm/sec (optimized automatically)
Radius of the stylus tip:	0.002 – 1 mm
Measurable gradients:	78° upwards; 87° downwards
VC-10 dimensions (W x T x H):	950 x 380 x 725 mm
VC-10-EL/-UL dimensions (W x T x H):	1150 x 380 x 725 mm
VC-10 weight (ca.):	150 kg
VC-10-EL weight (ca.):	180 kg
VC-10-UL weight (ca.):	200 kg
A certified calibration standard is supplied with the machine	

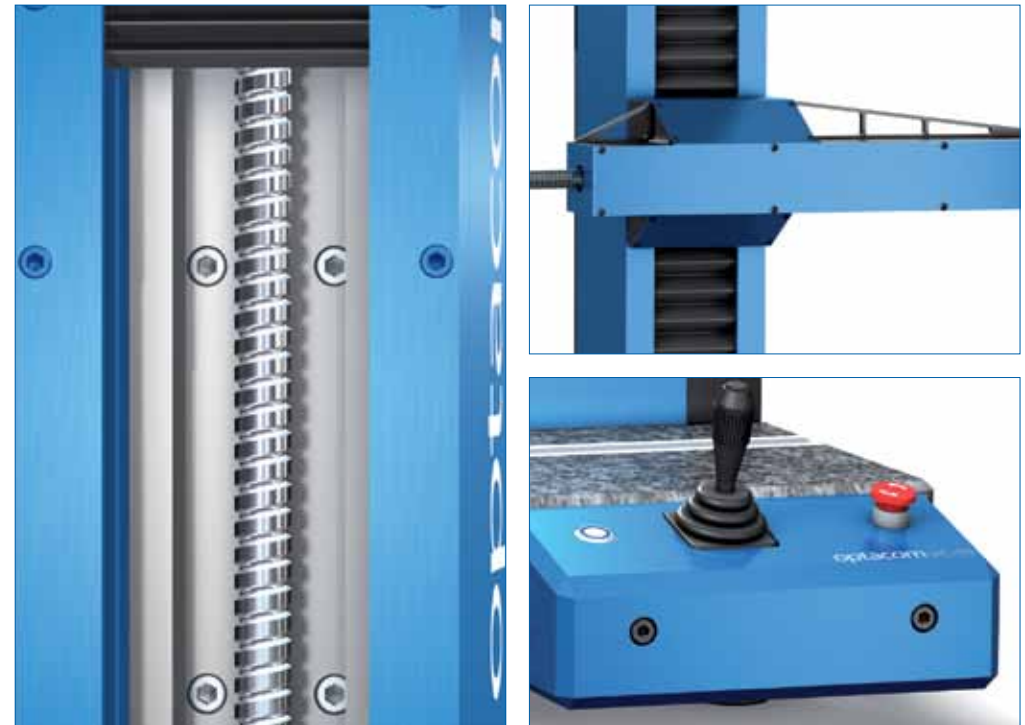

- ▶ The powerful all-round system for the entire variety of contour measurement tasks
- ▶ Contour and roughness in one measurement with the optional roughness module (see pages 24/25)
- ▶ Roundness measurements and composite measurements with optional rotary-swivel table (see page 13)
- ▶ Outstanding genuine resolution of 3 nm direct at the stylus tip
- ▶ Y-table optional (see page 10)
- ▶ Axis guide and head integrally made from one workpiece
- ▶ X axis permanently and absolutely backlash free connected to the Z axis
- ▶ High-precision linear axes with integrated drive
- ▶ Body made of high-strength aircraft aluminium
- ▶ Contactless and absolutely wear-free linear-incremental measuring system
- ▶ Machine calibration (including stylus tip calibration) in less than 3 minutes
- ▶ Quick stylus tip replacement with optacom quick-release fastener. No tools required and no accuracy loss
- ▶ Fully equipped basic system, including calibration standard, industrial PC with a minimum 21" TFT monitor, printer and optacom contour software module

Delivery scope:

Measuring machine optacom VC-10, industrial PC with a minimum 21" TFT monitor, mouse and keyboard, inkjet printer, Windows XP operating system, optacom contour software, calibration standard with certificate (for machine calibration purposes), two quick-release fasteners and two stylus tips

optacom VC-10		optacom VC-10-EL		optacom VC-10-UL	
horizontal / vertical (X axis/Z axis)	225 mm	horizontal / vertical (X axis/Z axis)	325 mm	horizontal / vertical (X axis/Z axis)	425 mm
Order no.: 101-204-010		Order no.: 101-204-325		Order no.: 101-204-425	

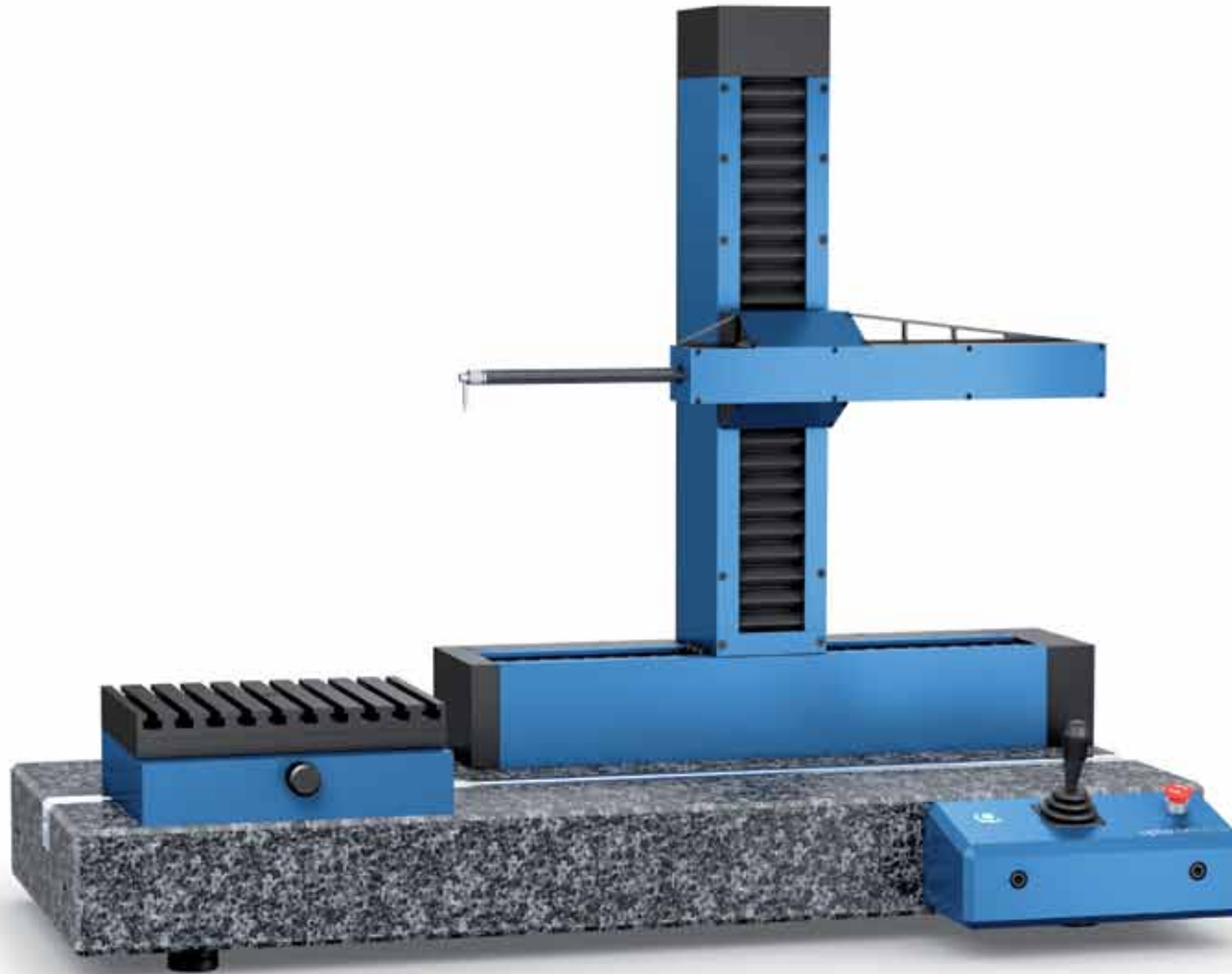

The optacom LC-10 represents the perfect entry model. Especially in cases where the entire scope of service of a modern universal measuring machine is needed, the optacom LC-10 is – compared to the high precision of a VC-10 – the most suitable product.

It covers the measuring range and features the technical refinements of our all-round machine VC-10, thus provides an

outstanding measuring accuracy. Therefore, the LC-10 combines in a single housing a perfect measurement quality and an attractive price.

The LC-10 is a real optacom measuring machine in every detail. It uses a high-precision linear axis with an integrated drive and wear-free, linear incremental system.

Its body is made of high-strength aircraft aluminium. The operation and the software modules used are identical to those found in other optacom measuring machines.

However, the LC-10 cannot be extended to a universal measuring machine with the optional rotary-swivel table.



Resolution in X and Z axis:	0.02 µm	Maximum measuring force:	10 - 150 mN
Resolution at the stylus tip:	0.03 µm	Measuring speed:	0.1 - 2 mm / sec (optimized automatically)
Measuring range (Z axis):	225 mm	Radius of the stylus tip:	from 0.002 to 1 mm
Measuring range (X axis):	225 mm	Angle measurement:	78 ° upwards; 87 ° downwards
Measuring system:	optical, incremental and contactless in all axes (X, Z, T)	Dimensions (W x D x H):	950 x 380 x 725 mm
Accuracy:	+/- (1.5 + L/100) µm	Weight:	150 kg

- ▶ The entry-level system for the entire variety of contour measuring tasks
- ▶ Contour and roughness in one single measurement with the optional roughness module (see pages 24/25)
- ▶ Very good resolution of 30 nm directly at the stylus tip
- ▶ Y-table optional (see page 10)
- ▶ Body made of high-strength aircraft aluminium
- ▶ Axis guide and head integrally made from one workpiece
- ▶ X axis permanently and absolutely backlash free connected to the Z axis
- ▶ Contactless and absolutely wear-free linear-incremental measuring system
- ▶ Machine calibration (including stylus tip calibration) in less than 3 minutes
- ▶ Quick stylus tip replacement with optacom quick-release fastener. No tools required and no accuracy loss
- ▶ High-precision linear axes with integrated drive

Scope of delivery:

Fully equipped basic system, including calibration standard with machine calibration certificate, industrial PC, minimum 19" TFT monitor, inkjet printer and optacom contour software module, one quick-release fastener and one stylus tip 33 mm

optacom LC-10	
horizontal / vertical (X axis/Z axis)	225 mm
Order no.: 101-206-001	

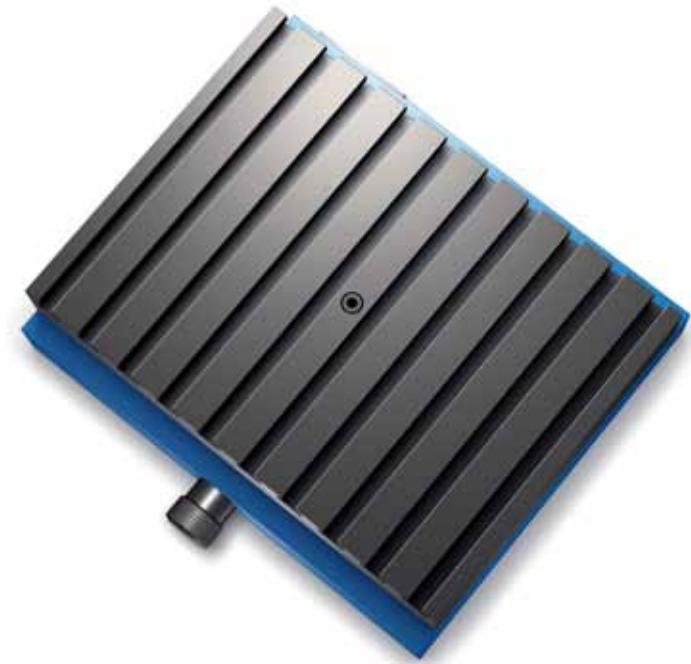

Tough, universal, accurate - optacom Y-tables - the perfect addition to your measuring machine.

Y-tables from optacom are universal and flexible, yet tough and highly accurate. So, all in all, typical optacom components. They are compact and their linear guides and ball screw drives allow a play-free and accurate movement.

The automatic Y-table also features a stepper motor and an optical, incremental and contactless measuring system.

optacom offers you the following three different versions:

Y-table manual YTM

To manually search for the highest / lowest point

Y-table automatic YTA-25 / YTA-100

To automatically search for the highest / lowest point

For the extension of automated CNC programs on the Y axis to obtain user-independent, reproducible top-down measurements in the micrometer range

The following specifications apply to all Y-tables:

YTA-25/YTM-25 length:	185 mm
YTA-100 length:	375 mm
Width:	250 mm
Height:	85 mm
Y-movement range:	25 mm or 100 mm
Spindle pitch:	3 mm
YTA-25 YTM-25 weight:	11 kg
YTA-100 weight:	17 kg
Table load:	500 kg

Automatic Y-table YTA-25

with 25 mm movement range

Order no.: 101-204-007

Automatic Y-table YTA-100

with 100 mm movement range

Order no.: 101-204-107

Manual Y-table YTM-25

with 25 mm movement range

Order no.: 101-204-004



Rotating swivel vise CHM-80

- ▶ Angle adjustment via a 3'-Nonius
- ▶ Adjustment screw to allow precise angle adjustment
- ▶ Form-fitted clamping in any desired angle position via locking screws

Length:	160 mm
Width:	110 mm
Jaw width:	75 mm
Span:	80 mm
Height:	137 mm
Horizontal adjustment:	360°
Swivel adjustment:	+/- 60°
Parallelism:	3 µm / 100 mm
Perpendicularity:	4 µm / 100 mm
Material:	1.1654
Hardened:	56° - 60° HRC
Weight:	14 kg

Rotating swivel vise CHM-80

Order no.: 101-202-003



Sine angle vise SA-100

- ▶ Made out of high-quality alloy steel, hardened and grinded
- ▶ Angle adjustment via gauge blocks
- ▶ Clamping system at the lower part allows a secure angle adjustment

Length:	130 mm
Width:	73 mm
Span:	45 mm
Height:	93 mm
Swivel adjustment:	45°
Parallelism:	3 µm / 100 mm
Perpendicularity:	5 µm / 100 mm
Material:	1.1654
Hardened:	58° - 62° HRC
Weight:	6 kg

Sine angle vise SA-100

Order no.: 101-202-010



Standard vise A-25

- ▶ Made out of high-quality alloy steel, hardened and grinded
- ▶ Very precise, closes absolutely gap-free
- ▶ Two integrated side clamping slots

Length:	140 mm
Width:	63 mm
Span:	85 mm
Height:	69 mm
Parallelism:	3 µm / 100 mm
Perpendicularity:	4 µm / 100 mm
Material:	1.1654
Hardened:	56° - 58° HRC
Weight:	4.6 kg

Standard vise A-25

Order no.: 101-202-020

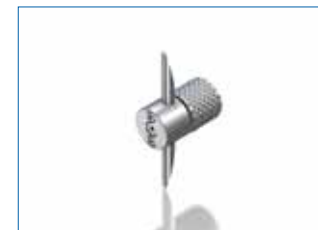
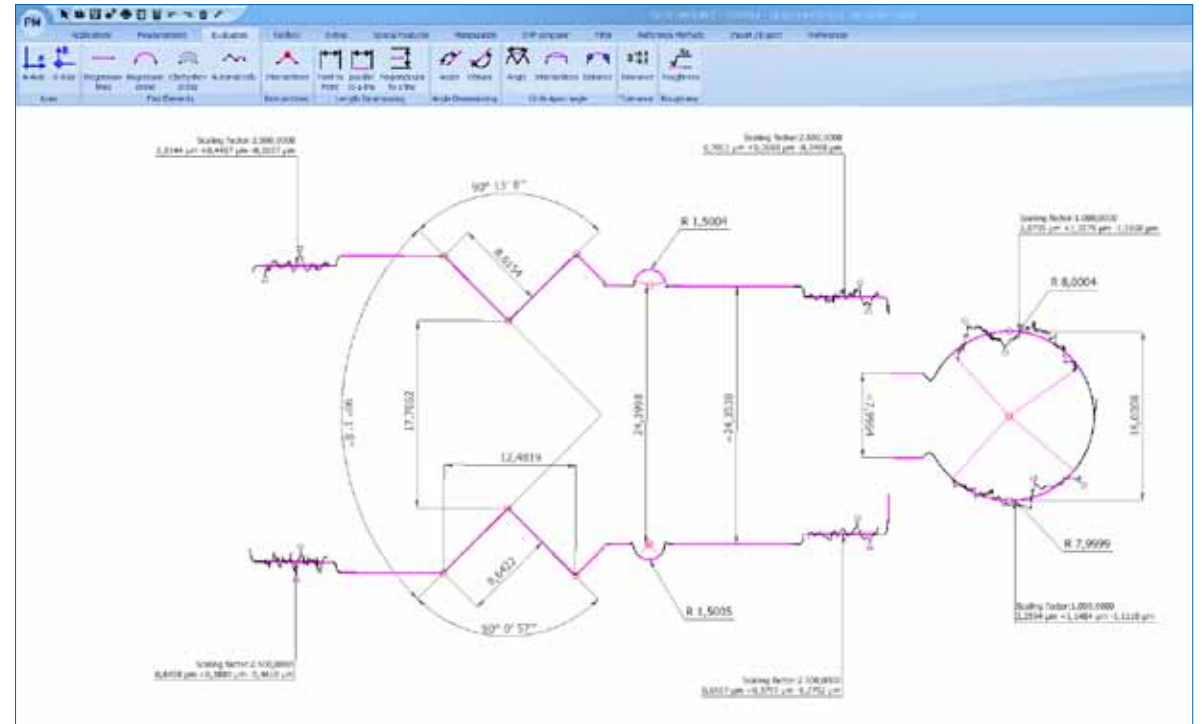

Of course, valuable knowledge on the dimensional stability of a component, e.g. thickness, angle or radii and their relation, can be gained by checking the upper and lower contour. But so far, the problem was that both contours had to be analysed in two different measurement runs and subsequently, had to be more or less correlated. Using optacom top down, this task will be fixed comfortably and precisely to your entire satisfaction – that you are used to at optacom.

Given that contour measurements obtained through our machines stand in precise dimensional relation with each other based on absolute coordinates from the very beginning, you can use optacom topdown to combine two (or more) sub-measurements in a straightforward and automatic fashion.

Scope of delivery:

optacom topdown software, double-sided calibration standard with certificate (for machine calibration purposes), a double stylus tip quick-release fastener, and two 20.5 mm stylus tips

topdown module

when ordering with machine

Order no.: 101-600-001

topdown module

retrofit kit

Order no.: 101-610-001

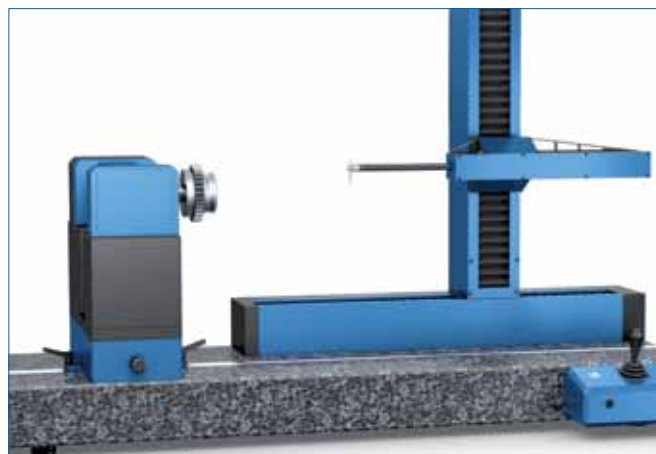

The new rotary-swiveling table RSY-240-25 from optacom combines the advantages of a round-table with the advantages of a swiveling specimen holder. Therefore, in addition to roundness measurements, this measuring table focuses specially on the automated (and therefore metrologically exact comprehensible) swiveling of components. Thus, it is possible for the first time to consistently measure, under clearly defined conditions, components with deep grooves and 90° insertions, as well as to capture flatness and roundness values that required multiple measurement passes before, and to combine the results of these individual measurements in an error-free, overall measurement report. Thus, the measurement is entirely simplified and also more precise, resulting in a noticeable decrease of measuring and evaluating efforts.

Like all our components, the optacom RSY 240-25 works ultra precisely. The default concentricity is achieved through a mechanical accuracy of 2.5 microns, which can be increased using special chucks to a value below 1 micron.

By default, the RSY 240-25 is delivered with a specially developed motorized Y-table with a measuring system and a movement range of 25 mm.

The integrated Y-table provides the ability to automatically search for the highest / lowest point and allows the expansion of the CNC mode on the Y axis.

The standard RSY 240-25 is delivered with a manual 3-jaw chuck

- ▶ Fully integrated in the optacom software
- ▶ Easy roundness measurement
- ▶ Absolute torsion resistant
- ▶ In-Out clamping
- ▶ Swing diameter over granite base of 190 mm
- ▶ Roughness fully measurable on the diameter at circumference
- ▶ Fully CNC programmable
- ▶ Movement controllable via machine console provided with buttons and joystick
- ▶ Three integrated optical, incremental and contactless measuring systems

Length:	365 mm
Width:	145 mm
Height:	255 mm
Y-movement range:	25 mm
Spindle pitch:	3 mm
Swivel angle:	+ / -120°
Weight:	30 kg
Maximum work piece weight:	15 kg

Rotary-swiveling table

Order no.: 101-710-010

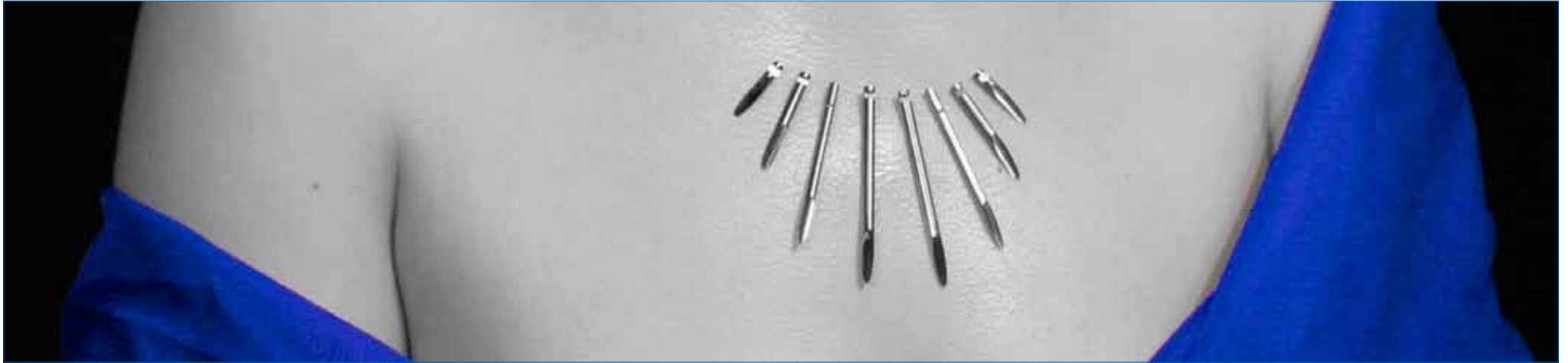

Stylus tip 59.5 mm **Order no.: 101-010-001**
made of carbide, Ø 3.5 mm / R: 25 µm / A: 12°
Mahr compatible (6851517)



Stylus tip 33 mm **Order no.: 101-010-002**
made of carbide, Ø 3.5 mm / R: 25 µm / A: 12°
Mahr compatible (6850286)



Stylus tip 20.5 mm **Order no.: 101-010-003**
made of carbide, Ø 3.5 mm / R: 25 µm / A: 12°
Mahr compatible (6850289)

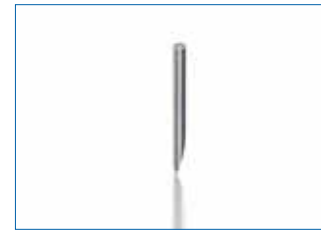

Stylus tip 13 mm **Order no.: 101-010-009**
made of carbide, Ø 1 mm / R: 25 µm / A: 19°



Stylus tips 6 mm * **Order no.: 101-010-004**
made of carbide, Ø 1 mm / R: 25 µm / A: 19°
Mahr compatible (6851518 / 6851527)

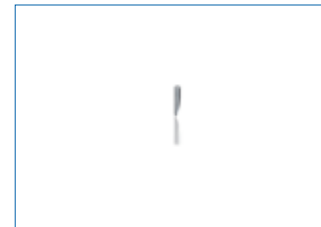

Stylus tip 3.5 mm **Order no.: 101-010-011**
made of carbide, Ø 0.5 mm / R: 25 µm / A: 19°

* For 6 mm stylus tips, we offer an exchange service for your Mahr stylus arm. For this, the existing tracing arm, in which the new stylus tip is glued, is necessary.

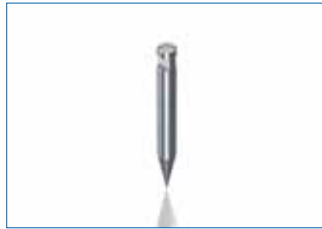

Conical stylus tip 33 mm Order no.: 101-010-007
made of carbide, Ø 3.5 mm / R: 25 µm / W: 24°
Mahr compatible (6851534)

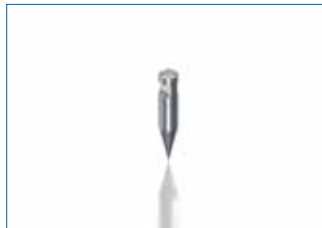

Conical stylus tip 20.5 mm Order no.: 101-010-008
made of carbide, Ø 3.5 mm / R: 25 µm / A: 24°
Mahr compatible

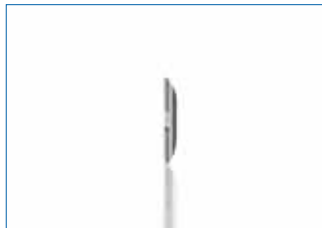

Double stylus tip 9 mm Order no.: 101-030-054
made of carbide, Ø 1 mm / R: 25 µm / A: 2 x 19°
suitable for top-down measurements



Roughness stylus tip 33 mm, conical Order no.: 101-005-002
made of carbide, Ø 3.5 mm / A: 24° with diamond tip /
R: 2 µm / W: 90°

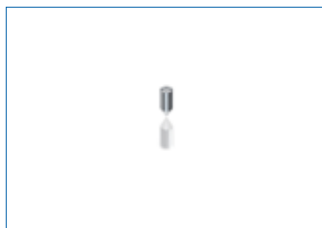

Roughness stylus tip 3 mm, conical, Order no.: 101-005-005
made of carbide Ø 1 mm / A: 24° with diamond /
R: 2 µm / W: 90°



Quick-release fastener Order no.: 101-010-080
for stylus tips with diameters of 3.5 mm



Quick-release fastener horizontal Order no.: 101-010-081
for horizontal extension with Ø 3.0 mm (miniature tracing arm / Disc stylus system)

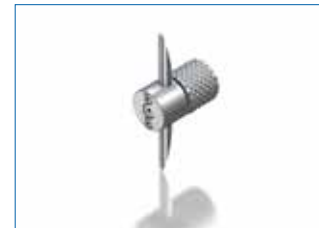

topdown-quick-release fastener Order no.: 101-630-001
for stylus tips with diameters of 3.5 mm for top-bottom measurements; delivery without stylus tips!



Miniature stylus arms for removable stylus tip Ø 1 mm Order no.: 101-010-060
including quick-release fastener, standard length 50 mm (other lengths upon request); delivery without stylus tips!



Miniature stylus arms with glued stylus tip Ø 3.5 mm Order no.: 101-030-023
including quick-release fastener, standard length 25 mm (other lengths upon request)



Disc stylus system 10 mm **Order no.: 101-030-913**
Disc stylus (see below) and arm extension, including quick-release fastener (QRF), length 51 mm from front edge of QRF



Disc stylus system 3 mm **Order no.: 101-030-911**
Disc stylus (see below) and arm extension, including quick-release fastener (QRF), length 25 mm from front edge of QRF

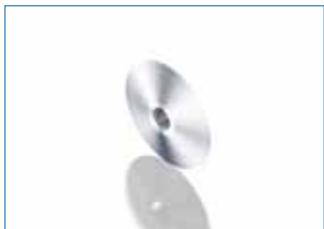

Disc stylus 10 mm **Order no.: 101-030-013**
single-item, made of carbide, \varnothing 10 mm / R: 25 μ m / A: 2 x 12°

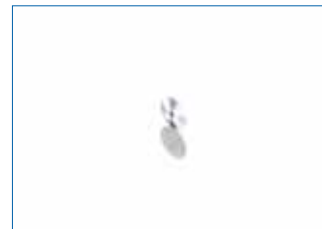

Disc stylus 3 mm **Order no.: 101-030-011**
single-item, made of carbide, \varnothing 3 mm / R: 25 μ m / A: 2 x 12°



Disc stylus system 6 mm **Order no.: 101-030-912**
Disc stylus (see below) and arm extension, including quick-release fastener (QRF), length 51 mm from front edge of QRF



Disc stylus system 1 mm **Order no.: 101-030-910**
Disc button (see below) including quick-releases fastener (QRF)

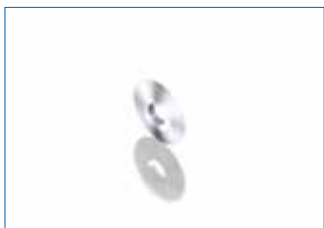

Disc stylus 6 mm **Order no.: 101-030-012**
single-item, made of carbide, \varnothing 6 mm / R: 25 μ m / A: 2 x 12°



Disc stylus 1 mm **Order no.: 101-030-010**
single-item, \varnothing 1 mm / R: 25 μ m / A: 2 x 12°, including extension (made of one piece - carbide), length 25 mm from front edge of quick-release fastener

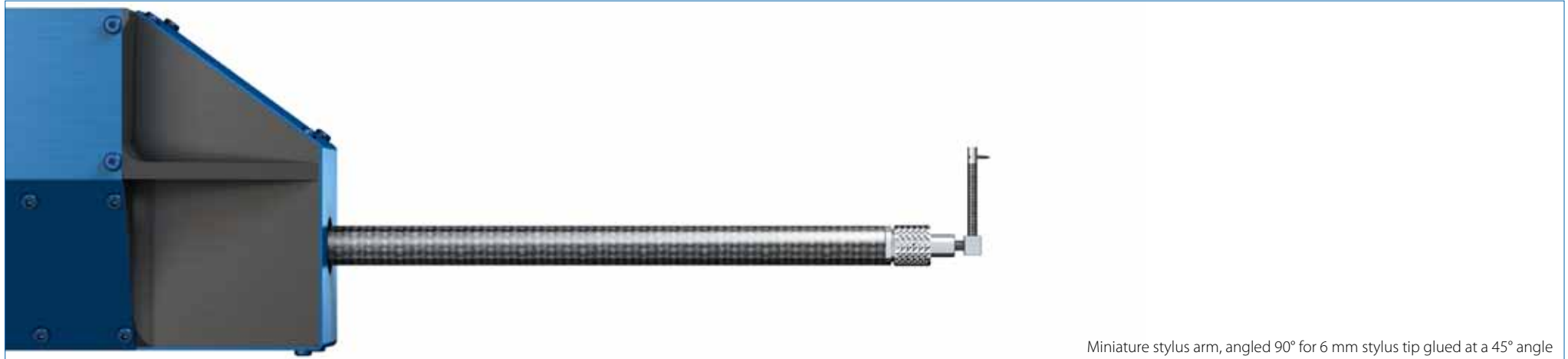

Miniature stylus arm, angled 90° for 6 mm stylus tip glued at a 45° angle

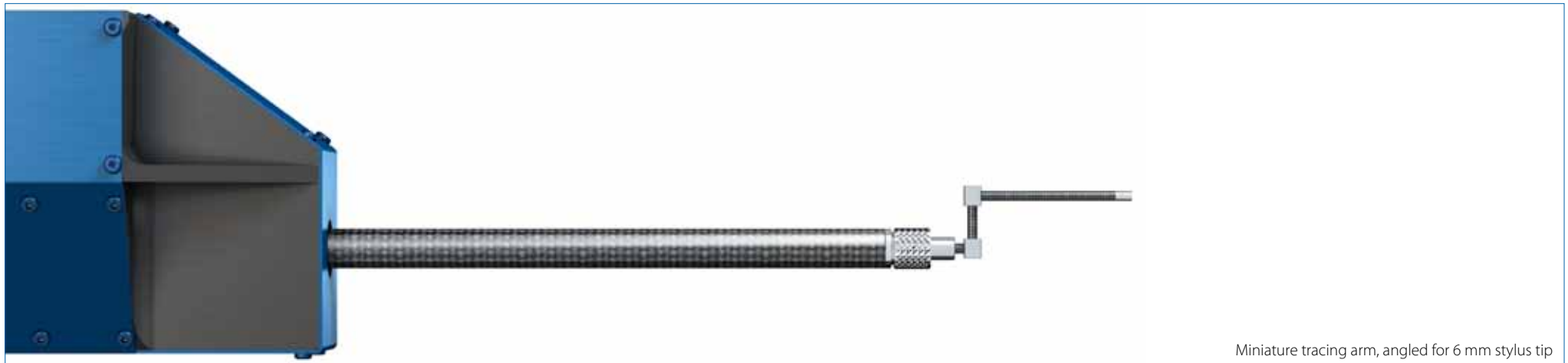

Miniature tracing arm, angled for 6 mm stylus tip

A chain is only as strong as its weakest link - a measurement system is only as good as its tracing arm and stylus tip. Thus, we pay serious attention to this detail – as we do to our machines. All stylus systems are manufactured with the same care as optacom's measurement systems.

Our practice oriented and cost reducing system of various stylus tips, disc styli, and miniature tracing arms can be replaced in seconds using the practical optacom quick-release fastener.

This is shown in the daily business of calibration and measuring labs in factories worldwide.

With your input, we develop and manufacture effective solutions to meet your specific measurement requirements.

We are looking forward to receiving your inquiry.





The software for contour measurements

The operation of our machines and software was originally designed to ensure stability and ease-of-use. The functional scope is considerably bigger, compared to similar machines with reduction of training. This also applies to our various software modules.

Using the optional optacom topdown module, an unlimited number of contours can be evaluated within a single representation and without loss of reference.

Using the optional roughness module optacom rough, Contour, roughness and waviness can be recorded and evaluated in one single measuring run.

Thanks to our also optional available software module optacom round, you can now, for the first time, measure contour, roundness, co-axiality and roughness in one single clamping.

One of the most striking arguments for all our software is the lifetime free software update.

optacom contour: functional overview

- ▶ Semi-automatic search of all elements with a single mouse-click
- ▶ Manual or automatic element adjustment and optimization
- ▶ Evaluation of radii, distances and angles
- ▶ Creation of intersection points between any elements
- ▶ Regression lines or regression circles
- ▶ Regression adjustment with specified Gaussian or Chebyshev circles
- ▶ Multi-part regression lines or regression circles
- ▶ Fitting of test balls with a given radius and a definable direction angle
- ▶ Auxiliary lines: Parallel, perpendicular, straight lines with definable angle and distance
- ▶ Auxiliary circles: Through several points at intersections with given diameter
- ▶ Auxiliary points: Coordinate points, contour points, contour intersections, etc.
- ▶ Finding the highest / lowest point of contours and elements with respect to a reference
- ▶ Numeric and graphical determination of form deviations on lines and circles
- ▶ Numerical and graphical straightness and profile depth of lines
- ▶ Circular opening angle for regression circles
- ▶ Ordinate guideline for regression circle and regression line
- ▶ Automatic dimensioning with tolerance assessment for repeat measurements
- ▶ Zoom from 1:1 to 5000:1 for the evaluation, independent from printing
- ▶ Comments and texts
- ▶ Export function to Q-DAS
- ▶ Export function to Excel
- ▶ Newly developed printing functions with various output options
- ▶ Multi-contour printout supports multiple contours on a sheet
- ▶ Flexible representation of your company data, company logo, part numbers, etc.
- ▶ Segmented measurements in the entire measuring range without loss of reference
- ▶ Stylus tips compensation for all stylus directions
- ▶ Fully automatic calibration of stylus tips
- ▶ Newly developed tools for evaluating ball screws
- ▶ DXF import and sheet comparison
- ▶ Reference part database Q-DAS compatible
- ▶ All reports can display the reference system
- ▶ Extensive element list displays all element details
- ▶ Part comparison can also be done with modified measurement conditions or lengths
- ▶ Simple red-green evaluation with tolerances

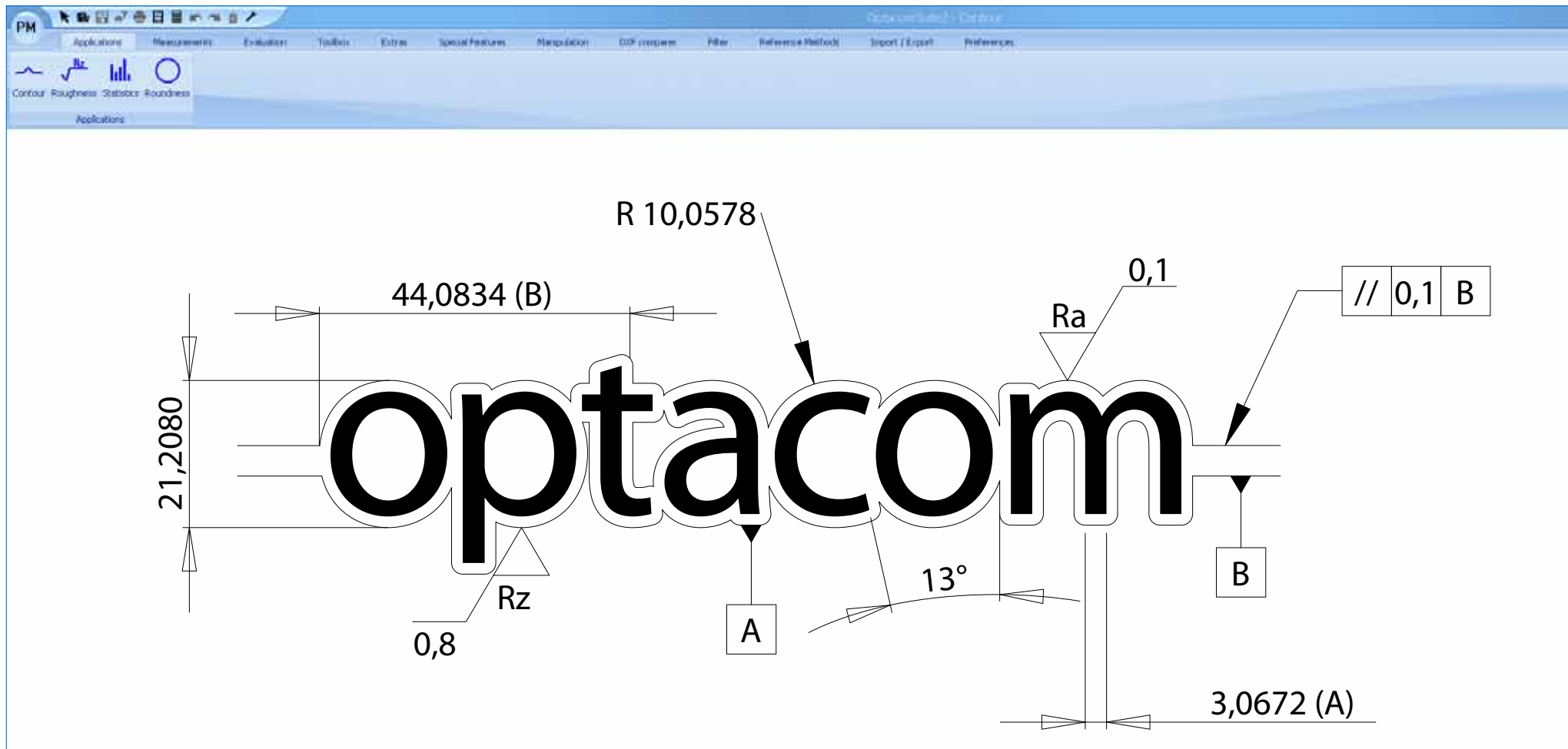

- ▶ Lifetime free software updates
- ▶ If required, software updates work fully automatic
- ▶ Single software interface for all modules
- ▶ Intuitive software solution, interface in low training requirements
- ▶ Using our roughness automation all incorrect measurements are excluded
- ▶ Q-Stat export interface also works with reference parts
- ▶ Integrated database fully compatible with Q-DAS
- ▶ New fault-tolerant reference part automation

- ▶ Fully automatic stylus tip calibration in less than 3 minutes
- ▶ Significant time savings through automatic element detection
- ▶ New algorithm for measuring ball screws and threads
- ▶ Due to our intelligent automatic functions, the evaluation time is reduced
- ▶ Integrated foil comparison with various integrations
- ▶ Well arranged list of elements
- ▶ References can be shown/hidden
- ▶ DXF import

- ▶ Very simple red-green tolerance comparison
- ▶ Contour, roughness and roundness analysis in a single evaluation
- ▶ Integrated form and position tolerances according to DIN ISO 1101
- ▶ User-customizable software interface
- ▶ Interface language can be changed during runtime
- ▶ Integrated online diagnosis tool in the event of problems
- ▶ Software includes statistical functions

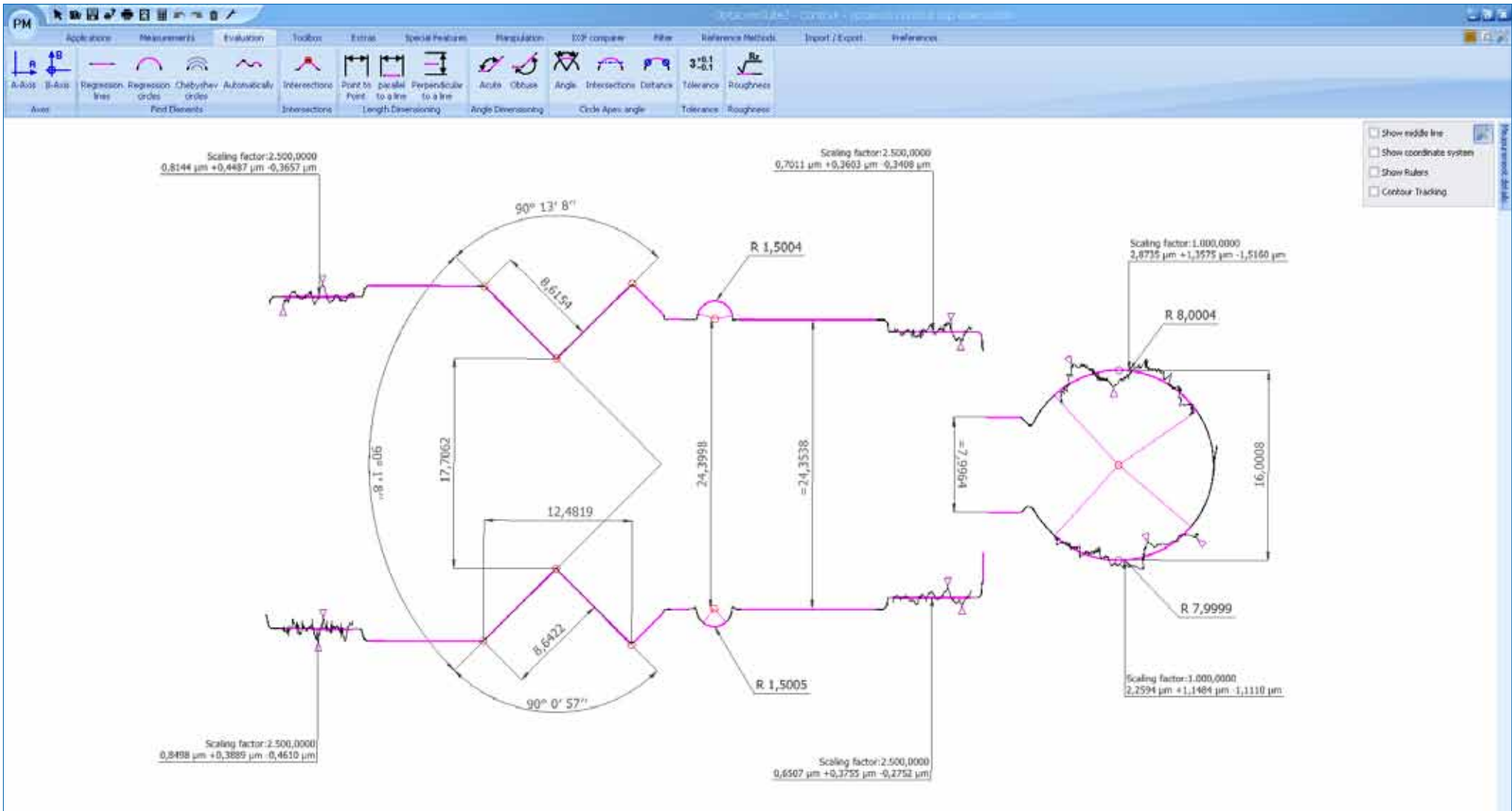

Evaluation made easy

Any number of contours can be evaluated with absolute dimensional reference to each other. After one or more measurements, the measured contours appear on the analysis screen. At this point, there are several possibilities available to search for elements on the measurement. For example, you can search for elements in a semi-automatic fashion using your own criteria.

Moreover, you may create elements by double-clicking at any position. Should you require regression radii, you can calculate them according to the Gaussian or Chebyshev specification. As shown in the upper evaluation screen, you can graphically over-extend the form deviation and display the numeric Pt value. In addition, you can create angles for any quadrant with just two

clicks. As shown by the evaluation above, you can evaluate angles as well as distances between all measured contours. Using the extrema function, it is possible to determine the greatest or smallest distances of evaluated elements or contours.

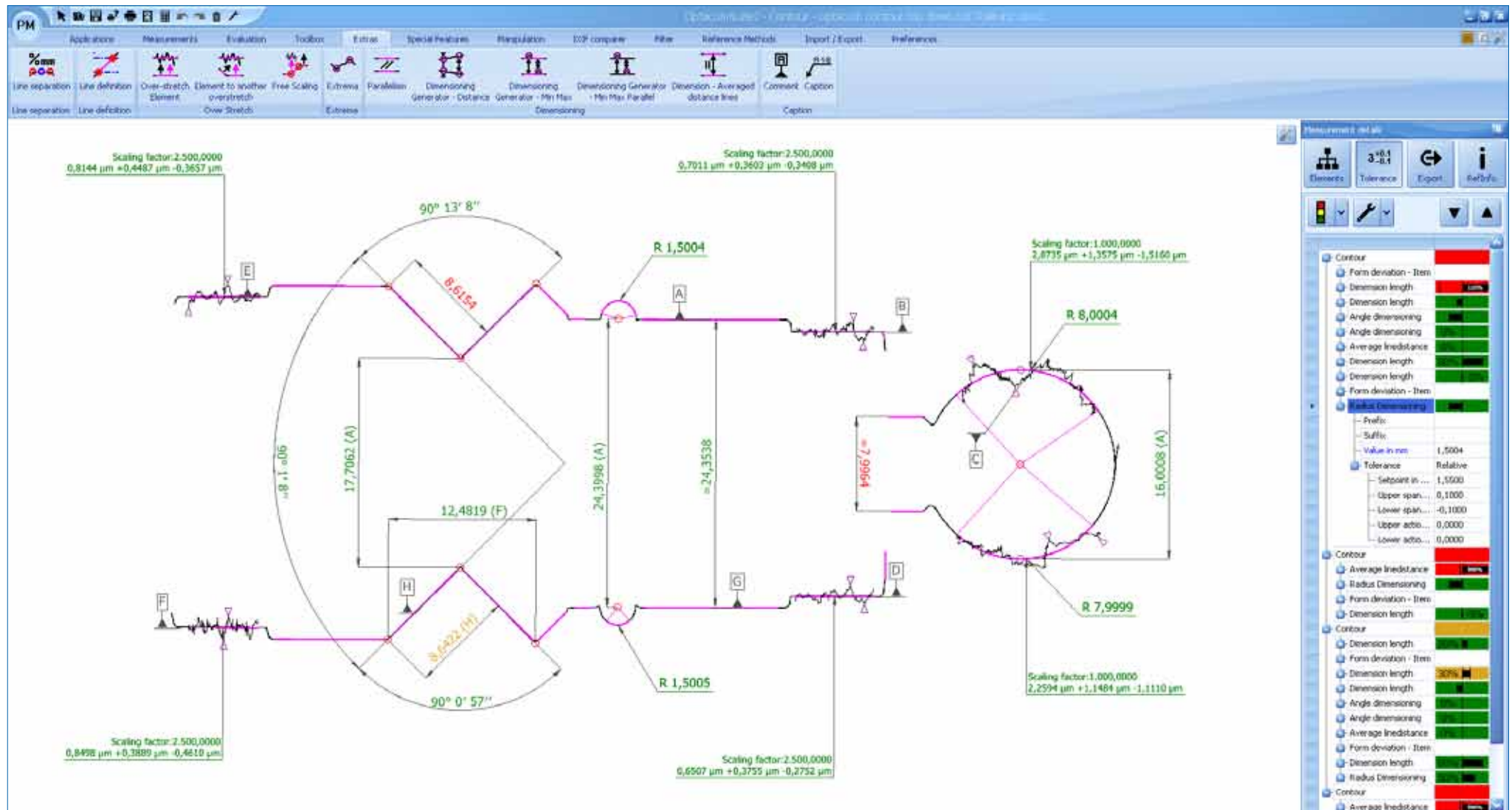

Good to know that everything fits

When evaluating serial parts, you have the possibility of indicating tolerances. After a fully automatic evaluation through our unique reference run, you can immediately find out whether your part is OK or not. The advantage of the element list is in the display of the existing tolerance percentage, in addition to the red-green evaluation. This indicates the exhausted and re-

maining tolerance. This feature prevents unwelcome surprises, as you can immediately see whether you need to counteract the process, thereby avoiding late interventions associated with the usual red-green evaluation. Furthermore, our tolerance evaluation allows defining intervention limits. These limits are shown in yellow colour when it is time to act. It is possible

to assign a tolerance value to any elements. This works naturally across contours. Simply click on the desired value and type the reference and tolerance value.

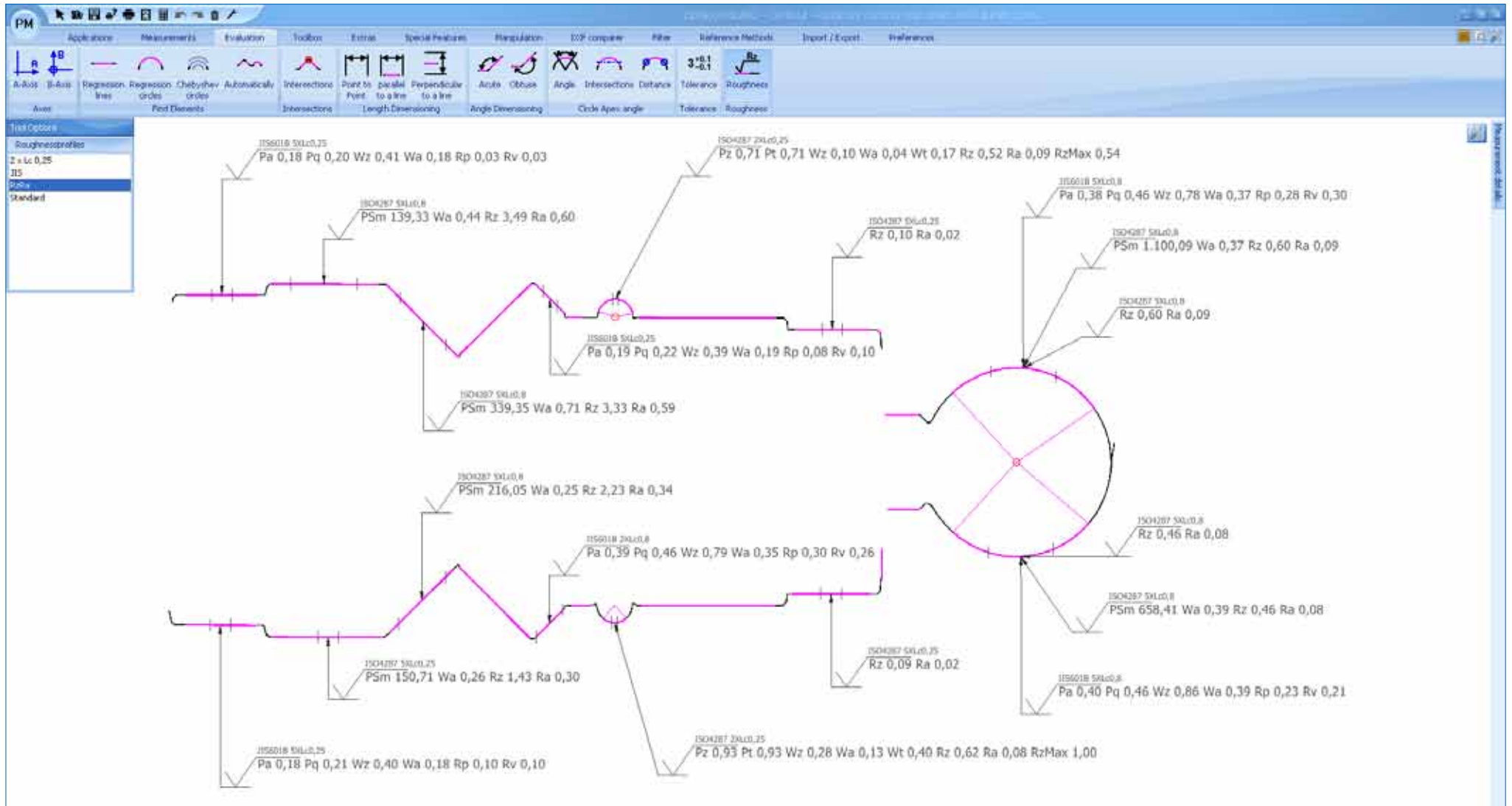

Roughness easy as pie with optacom rough

With our newly developed software algorithms, inexperienced operators are capable to create DIN ISO-compliant measurements for the first time. Our intelligent algorithms analyse the contour underlying and automatically calculate the proper cut-off and the compliant cut-off counts. Just another priceless advantage is the permanent horizontal position of our tracing

arm, which allows roughness measurements on all elements without restrictions to the stylus movement. You may find various examples of falling and rising contours and radii in the example above. Needless to say, unrestricted overhead roughness evaluations are also supported.

Furthermore, the roughness evaluation is completely integrated in the reference run. A further advantage is the possibility of performing different evaluations on one and the same line or radius. In that respect, the ball evaluation above provides an interesting example.

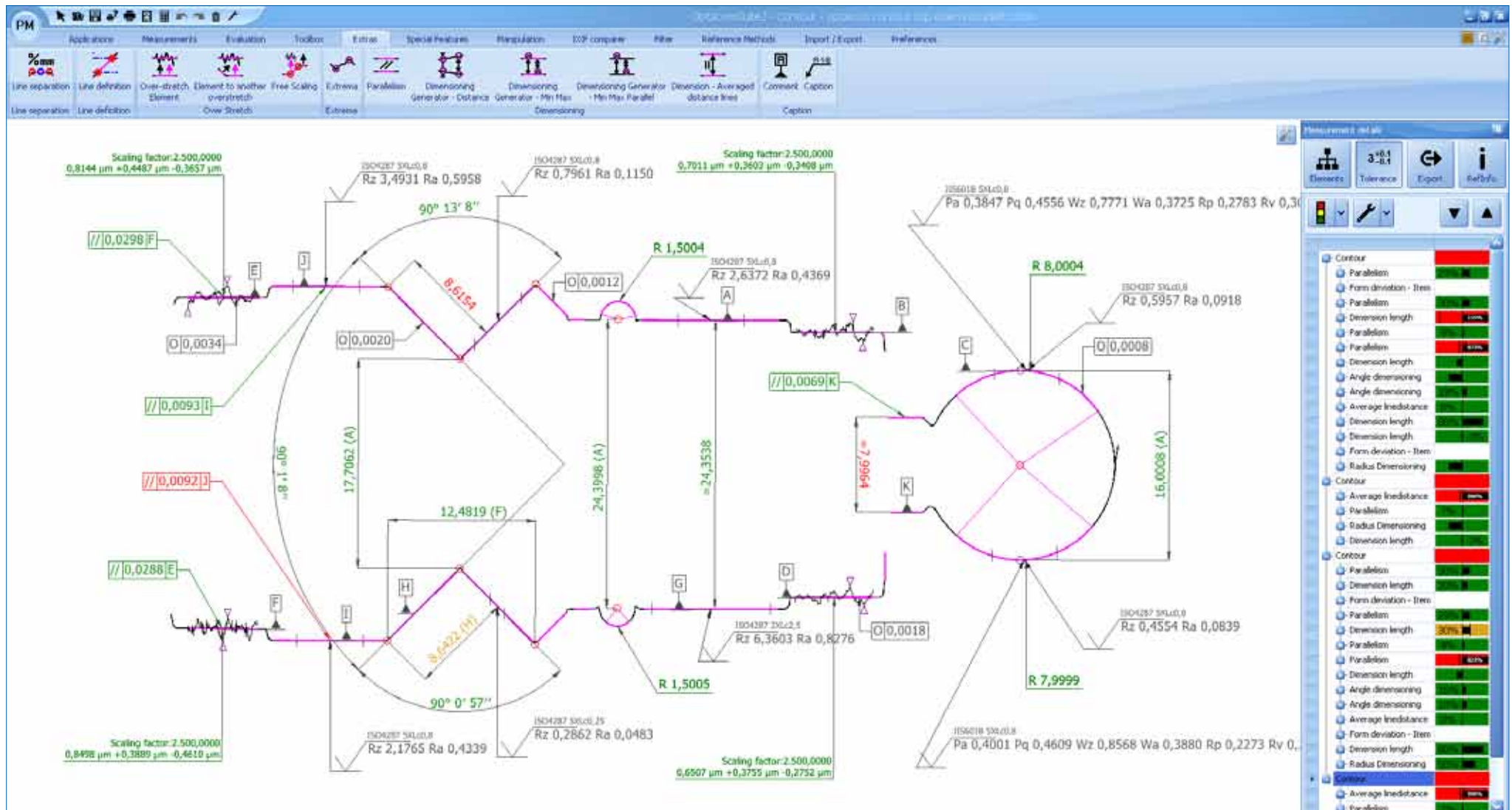

Contour, roughness, roundness, top-down - one software fits all

Our optacom rough and optacom round software modules allow you to create multiple profiles. Upon creation, you define uniquely to which norms they should evaluate. These profiles can then easily be used in our software optacom contour – simply by an mouse click. This means that you do not need to adjust any settings when evaluating roughness and roundness.

Moreover, all evaluations will be created DIN-compliant and fully automatic. To top this function off, you not only have a large time-saving, but also the reassuring feeling that possible failures cannot happen anymore. In the same easy and trouble-free way in which you create roughness and roundness evaluations, you can obtain form, orientation and position evaluations,

which are already integrated in the optacom contour software module. After having analyzed all required evaluations, you can then focus on printing. Thanks to our print processor, which has an integrated user database as well as customer profiles, you are able to save your reports as a PDF-document and to send it via email – and this with just a few clicks.



- ▶ Significant time savings
- ▶ Contour and roughness evaluations in a single measurement run
- ▶ No incorrect evaluations because of cut-off and filtering automatic
- ▶ Due to profiles, technical knowledge is not needed
- ▶ Several different standards on an single evaluation profile
- ▶ Significant cost savings through the use of carbide stylus tips instead of usual diamond stylus tips
- ▶ Roughness evaluation on lines, radii and on inclined surfaces; also on top down and roundness measurements
- ▶ Graphical and numerical representation of all reports
- ▶ Fully automatic calibration of carbide and diamond stylus tips
- ▶ Overhead evaluation of roughness
- ▶ Factory calibration of roughness makes on-site calibration unnecessary
- ▶ Roughness automatic facilitates DIN-compliant evaluations
- ▶ Roughness evaluation is automatically integrated in reference run

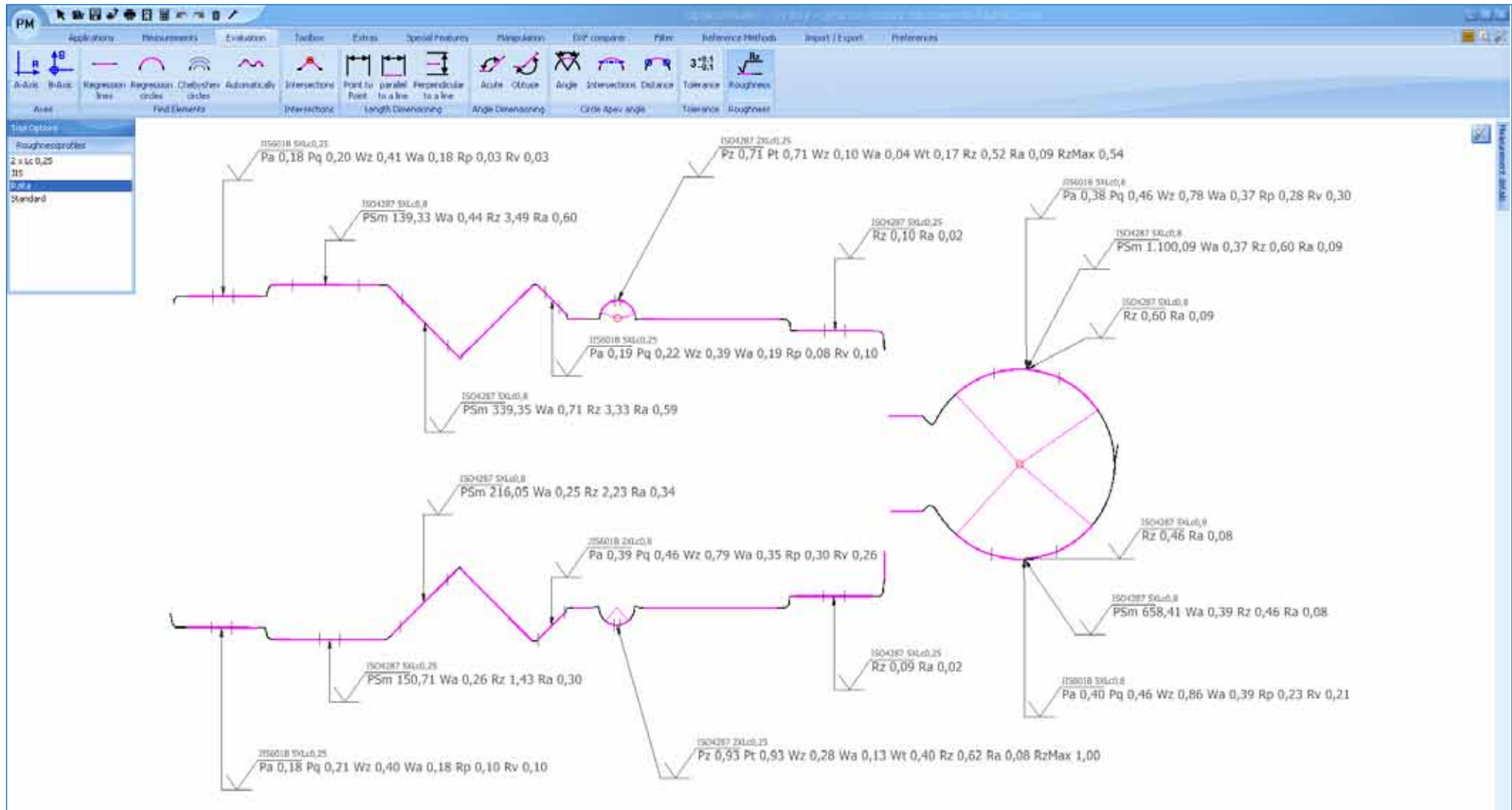

EN ISO 4287/ JIS B 0601

Pp	Pv	Pz	Pc	Pa	Pq	PSm	Pdq	Pdc	Pt	Pku	Psk	Pmr
Wp	Wv	Wz	Wc	Wa	Wq	WSm	Wdq	Wdc	Wt	Wku	Wsk	Wmr
Rp	Rv	Rz	Rc	Ra	Rq	RSm	Rdq	Rdc	Rt	Rku	Rsk	Rmr

EN ISO 12085 (Motif)

AW	W	Wx	Wt
AR	R	Rx	

EN ISO 13565 – 2

Mr1	Mr2	A1	A2	Rpk	Rvk	Rk
-----	-----	----	----	-----	-----	----

Scope of delivery for

optacom rough software:

Software package only

Scope of delivery for

optacom rough complete:

Software package, one diamond stylus tip, roughness standard, Quick-release fastener

optacom rough Software

Order no.: 101-203-020

optacom rough complete

Order no.: 101-203-001

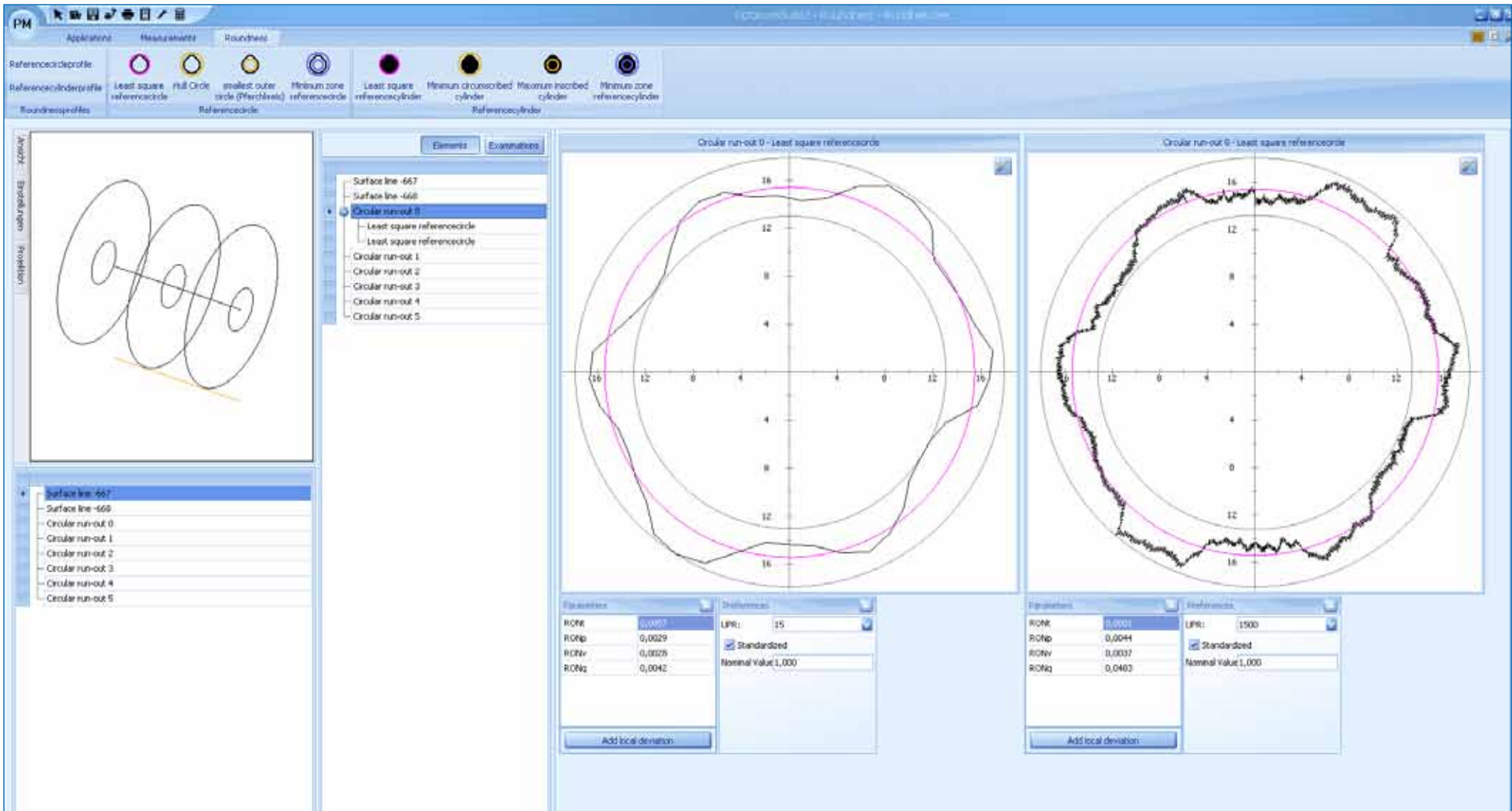

- ▶ Contour, roughness and roundness evaluation in a single measurement run
- ▶ Increased accuracy because the workpiece needs no reclamping
- ▶ Software based calibration and alignment of the workpiece holder
- ▶ Significant time savings thanks to our 4 in 1 concept

- ▶ Extremely reduced footprint
- ▶ Extremely simple operation through the joystick integrated in machine console
- ▶ Accurate, quick, and reproducible measurements possible without technical knowledge
- ▶ Customizable graphical interface to increase efficiency
- ▶ Quick and practically oriented evaluations

- ▶ Automatic filter adjustment
- ▶ Display of evaluable characteristics
- ▶ Illustration of evaluable features, according to DIN ISO 1101
- ▶ User-selectable evaluations of local form deviations

The extension module for roundness measurements

Form tolerances:

—	Straightness
▭	Flatness
○	Roundness
⊘	Cylindricity
⌒	Line form
⊂	Surface form

without reference specification

Position tolerances

//	Parallelism
⊥	Perpendicularity
∠	Angularity
◎	Coaxiality, Concentricity
≡	Symmetry
↗	Circular run-out
↗↗	Total run-out

with reference specification

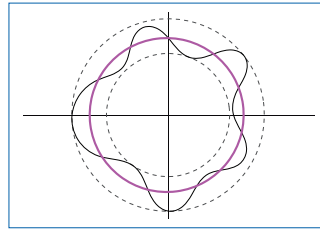

LSCI:
Least Square Circle

Regression circle such that the sum of the squares of the local roundness deviations is a minimum

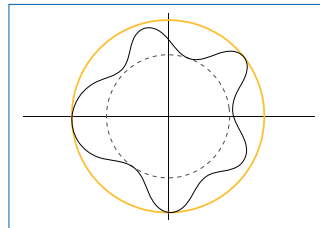

MCCI:
Minimum Circumscribed Circle

Smallest circle circumscribing the roundness profile

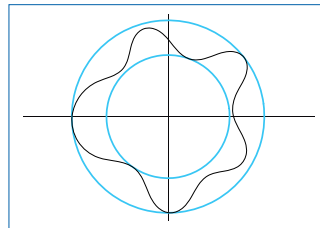

MZCI:
Minimum Zone Circle

Two concentric circles enclosing the roundness profile and having the least radial separation

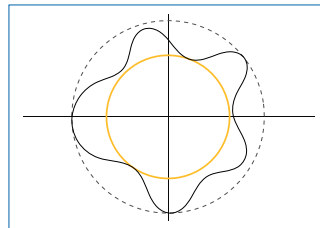

MICI:
Maximum Inscribed Circle

Largest inscribed circle in the roundness profile

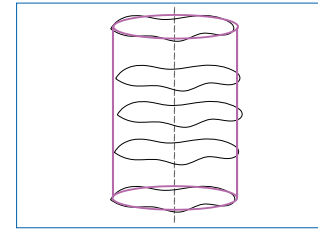

LSCY:
Least Square Cylinder

Regression cylinder such that the sum of the squares of the local roundness deviations is a minimum

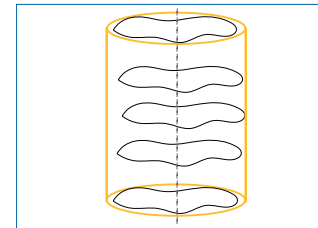

MCCY:
Minimum Circumscribed Cylinder

Cylinder with the smallest possible diameter encompassing the measured cylinder surface

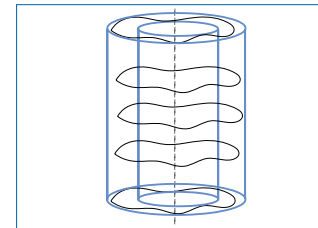

MZCY:
Minimum Zone Cylinder

Two concentric cylinder enclosing the roundness profile and having the least radial separation

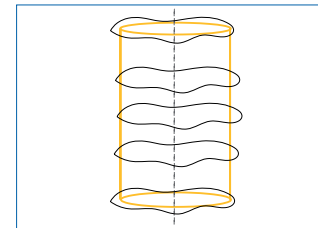

MICY:
Maximum Inscribed Cylinder

Cylinder with the largest possible diameter inscribed in the measured cylinder surface

Complete the product range with precision

The extension module for roundness measurements.

Your measuring programme can be perfectly rounded up with our software optacom round and our rotary-swivel table. In this combination, it is possible to evaluate and measure contour, roughness and roundness simultaneously (if roughness module optacom rough is installed).

Easy, fast, and comfortable measurements based on a high-precision, program-based operation.

Filtering method for roundness evaluation

Filter definition according to DIN EN ISO 11562: Cut-off numbers: 15, 50, 150, 500, 1500 W/U, arbitrary

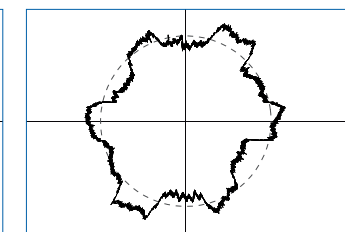
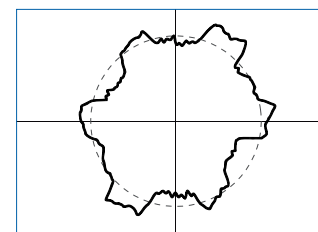
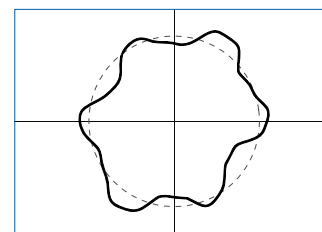



The optical inspection system

The optical inspection system „OIS“ helps to avoid incorrect measurements caused by damaged or worn stylus tips. Moreover, you do not need to worry about unnecessarily caused costs by too soon replaced stylus tips. Another advantage of this system is the seamless integration in our software optacom Suite 2.

All advantages at a glance:

- ▶ Optical control of your stylus tips with minimal effort
- ▶ Documentation of your stylus tips with one click with the supplied software
- ▶ Reduction of incorrect measurements caused by damaged stylus tips
- ▶ Reduction of costs of prematurely replaced stylus tips
- ▶ Reliability on contour, roughness and roundness measurements
- ▶ Intuitive and easy-to-use software
- ▶ 1280 x 960 pixels image resolution
- ▶ USB compatible, plug & play microscope
- ▶ Equipped with eight white LEDs for optimum illumination
- ▶ Increases your stylus tip up to 200-times
- ▶ 1.3 megapixel camera for razor sharp images of your stylus tips

Scope of delivery:

OIS with camera, USB cable, operating instructions, stylus tip holder order no. 101-217-101

Technical data:	
Magnification:	10 to 200-times
Connection:	USB 2.0
Shutter speeds:	1 sec. to 1 / 1000 sec.
Operating system requirements:	Windows 98SE / ME / 2000 / XP / Vista

optacom OIS

optical inspection system

Order no.: 101-217-000

PM OptacomSuite2 - Inspection System

Applications Inspection System

Photo File Edit

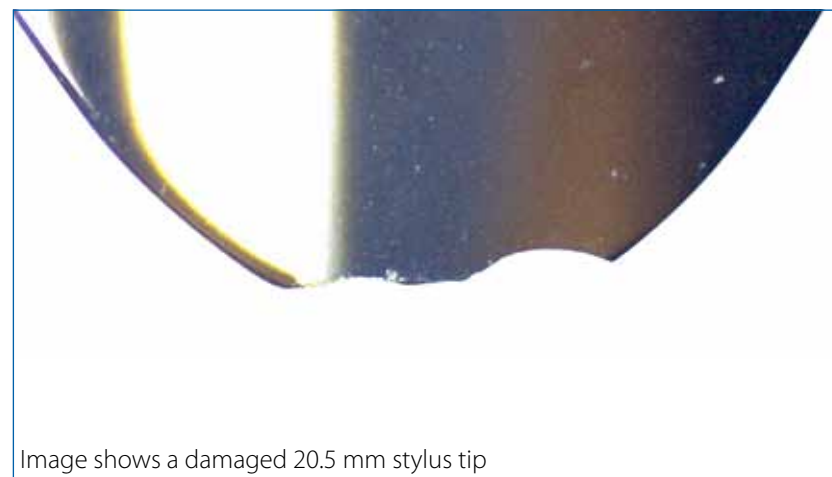
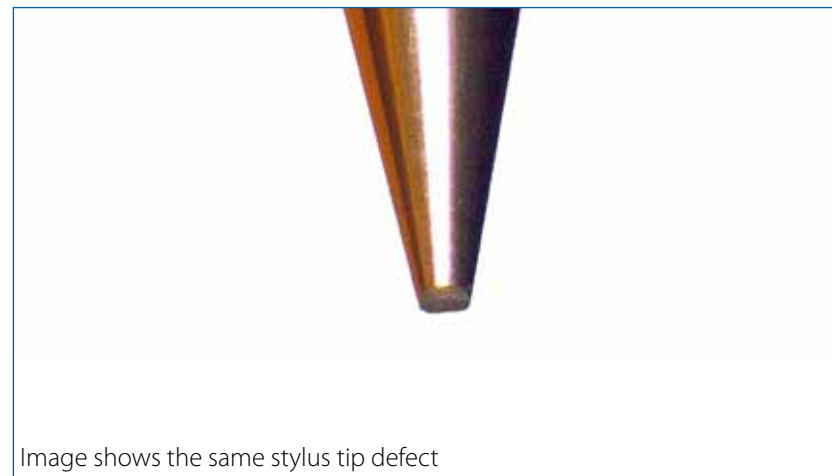



Stylus tip holder 0° - 90°
with two optacom quick-release fasteners
Order no.: 101-217-100



Stylus tip holder 45° rotation
including collet chuck and collet of your choice
Order no.: 101-217-102



Stylus tip holder 45°
with optacom quick-release fastener
Order no.: 101-217-101



Stylus tip holder 0° movable and rotating
including collet chuck and collet of your choice
Order no.: 101-217-103



Panel PC 17" with touchscreen IP64
40 GB SSD and Windows XP Professional
Intel Atom N270 1.6 GHz, 1 GB DDR 2
Resolution 1280 x 1024 pixels
Order no.: 101-217-300

Stand for Panel PC 17"
Order no.: 101-217-301

Wall mount for Panel PC 17"
Order no.: 101-217-302



Panel PC 19" with touchscreen IP64
40 GB SSD and Windows XP Professional
Intel Celeron Mobile 1.0 GHz, 1 GB DDR 2
Resolution 1280 x 1024 pixels
Order no.: 101-217-310

Stand for Panel PC 19"
Order no.: 101-217-311

Wall mount for Panel PC 19"
Order no.: 101-217-312

Collets:

Order no.:	Description:
101-217-200	Collet ER8, \varnothing 0.5 – 1.0 mm
101-217-201	Collet ER8, \varnothing 1.0 – 1.5 mm
101-217-202	Collet ER8, \varnothing 1.5 – 2.0 mm
101-217-203	Collet ER8, \varnothing 2.0 – 2.5 mm
101-217-204	Collet ER8, \varnothing 2.5 – 3.0 mm

Order no.:	Description:
101-217-205	Collet ER8, \varnothing 3.0 – 3.5 mm
101-217-206	Collet ER8, \varnothing 3.5 – 4.0 mm
101-217-207	Collet ER8, \varnothing 4.0 – 4.5 mm
101-217-208	Collet ER8, \varnothing 4.5 – 5.0 mm
101-217-210	9-pcs. Collet ER8

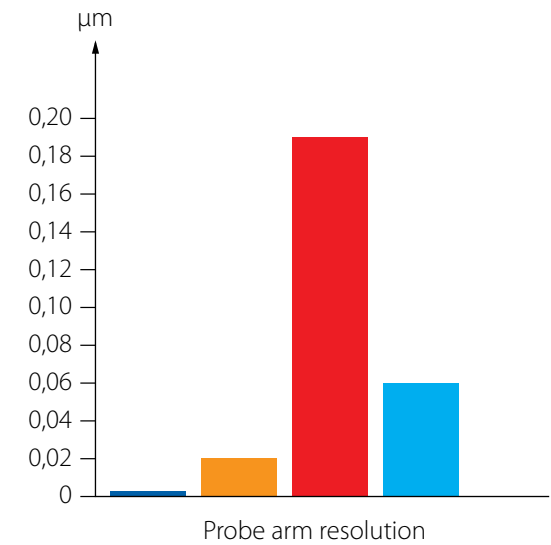
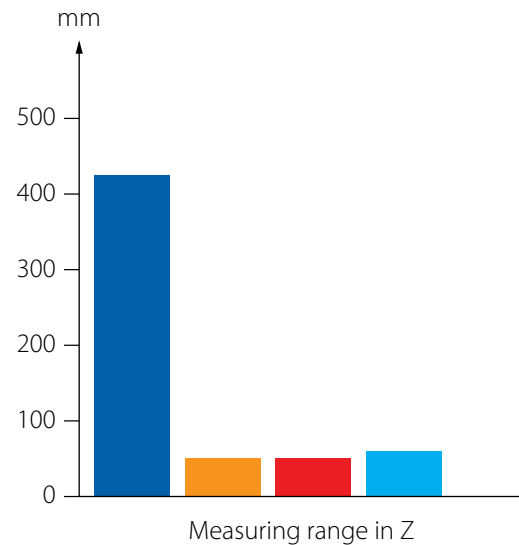
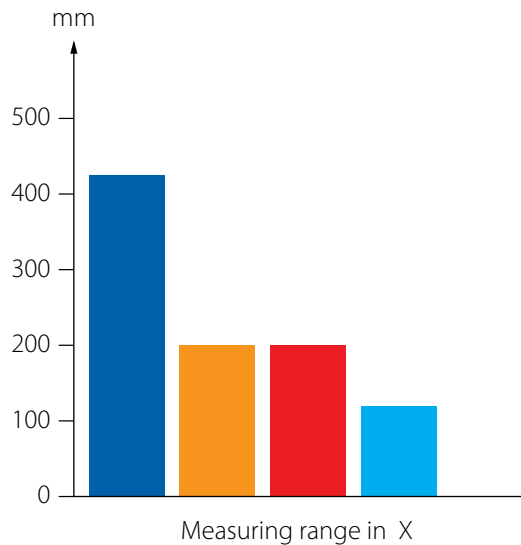

■ optacom ■ Manufacturer x ■ Manufacturer y ■ Manufacturer z

Overview of the operation-relevant standards embedded in our software:

- DIN EN ISO 1101 Geometrical Product Specifications (GPS) - Geometrical tolerancing - Tolerances of form, orientation, location and run-out
- EN ISO 4287 Geometrical Product Specifications (GPS) - Surface texture: Profile method - Terms, definitions and surface texture parameters
- EN ISO 4288 Geometrical Product Specifications (GPS) - Surface texture: Profile method - Rules and procedures for the assessment of surface texture
- EN ISO 12085 Geometrical Product Specifications (GPS) - Surface texture: Profile method - Motif parameters
- EN ISO 12562 Geometrical Product Specifications (GPS) - Surface texture: Profile method - Metrological characteristics of phase correct filters
- EN ISO 13565-1 Geometrical Product Specifications (GPS) - Surfaces having stratified functional properties-Filtering and general measurement conditions
- EN ISO 13565-2 Geometrical Product Specifications (GPS) - Surfaces having stratified functional properties - Height characterization using the linear material ratio curve
- JIS B 0601 Surface texture: Profile method - Terms, definitions and surface texture parameters

- DIN EN ISO 12180-1 Geometrical product specifications (GPS) - Cylindricity - Part 1: Vocabulary and parameters of cylindrical form
- DIN EN ISO 12181-1 Geometrical Product Specifications (GPS) -Roundness - Part 1: Vocabulary and parameters of roundness
- DIN EN ISO 12780-1 Geometrical Product Specifications (GPS) - Straightness - Part 1: Vocabulary and parameters of straightness
- DIN EN ISO 12781-1 Geometrical product specifications (GPS) - Flatness - Part 1: Vocabulary and parameters of flatness
- VDI / VDE 2631 Sheet 1 Form measurement - Principles for the determination of form and position deviations
- VDI / VDE 2631 Sheet 2 Form measurement - Determination of the sensitivity of signal-transmission chain
- VDI / VDE 2631 Sheet 3 Form measurement - Characteristics and selection of filters

optacom GmbH & Co. KG

- ▶ Dürrfelder Straße 18 • D-97508 Obereuerheim
- ▶ Telephone: +49 (0)9729 90971-0 • Fax: +49 (0)9729 90971-29
- ▶ E-Mail: office@optacom.com • Internet: www.optacom.com

optacom

Measurement technology - Made in Germany