



# Talyrond 131 and 130

For economical, high precision inspection of roundness and circular geometry.

**Process control** right at the point of manufacture is cost effective and convenient. Correlation between multiple units is assured thanks to exacting specifications.

**Quality control** at a central inspection station or in the gauge room is comprehensive and in full accordance with international metrology standards.

## Measuring excellence

The degree of excellence for any gauging device is its range to resolution. Taylor Hobson gauge heads, with wide range and selectable resolution, vastly improve the measure of precision in your manufacturing process.

- Wide range - 2mm (0.078")  
- simplifies initial set-up of the component and eliminates the need for special fixtures
- Normal resolution - 30nm (1.18 $\mu$ " ) - is ideal for most measurement requirements
- High resolution - 6nm (0.24 $\mu$ " )  
- used when component deviations are less than 0.40mm (0.016")



wide range gauge with wrist assembly provides high resolution in any attitude or orientation



Talyrond 131 shown with optional connecting rod loading platform which allows for comparison of the pin bore axis to the crank bore axis. Customized workholding devices can be used to expand capability (as above) or simply increase throughput.

## Powered by $\mu$ ltra Roundness software

$\mu$ ltra software provides comprehensive analysis and programmable measurement capabilities for the Talyrond 131 and 130 instruments. It is the ideal tool for any environment where rapid component inspection is desired.

# World leading performance

Both Talyrond 130 and Talyrond 131 incorporate a number of industry leading features that combine to deliver high accuracy, repeatability and ease of use.

## Mechanical excellence throughout the measuring loop

### Diamond turned air bearing spindle

Spindle accuracy is crucial to the performance of any roundness instrument. Radial limit of error is a constant value measured at the table top. Coning error, how well the spindle rotates on its axis, increases relative to distance above the table top. Although radial error can be improved through software correction, coning error can be minimized only through meticulous construction. Taylor Hobson's ultra high precision spindle provides the best combination of precision and "stiffness" in the world. The result is coning error less than  $0.00025\mu\text{m}/\text{mm}$  ( $0.25\mu\text{"/inch}$ ).

### Versatile gauging

The measuring gauge is carried in a "wrist" assembly for rapid changeover between vertical and horizontal attitudes while maintaining the exact center point of the stylus contact ball. Vertical for internal and external surfaces; horizontal for surfaces which may be upper or lower, external, angled or conical.

### High density zinc alloy base

Compact design is important for the workshop where tabletop space is always at a premium. Taylor Hobson uses a special zinc alloy casting to assure that small size does not compromise performance. This dense material is extremely stable even under typical production floor conditions.

### Integrated vibration isolation

As a further guarantee that laboratory grade metrology is attained on the shop floor, vibration isolation pads are built into both the Talyrond 130 and 131 instruments. In all but extreme circumstances no additional anti-vibration materials are required.

### Engineering assisted center and leveling

The centering and leveling knobs are differentiated by look and feel, allowing operators to view the screen while setting the component to the spindle axis. In addition, the neutral tilting plane is at a height above the tabletop that facilitates the leveling of both short and tall components.

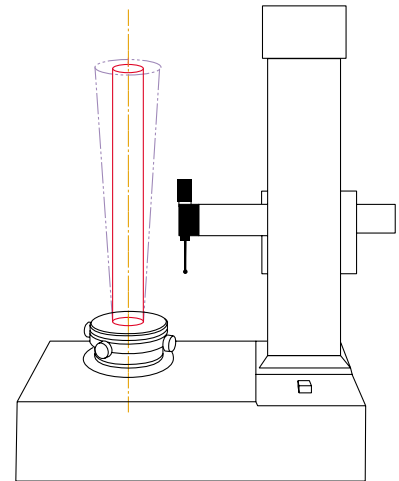

tall components can be measured with confidence and accuracy because coning error is minimized to a remarkable  $0.00025\mu\text{m}/\text{mm}$  ( $0.25\mu\text{"/inch}$ )



gauge arm in horizontal attitude with orientation downward to measure top face



gauge arm in vertical attitude with orientation retracted to measure an inside diameter

# µltra Software

µltra was developed first of all to function in accordance with the highest standards of metrology. That it turned out also to be clever, comprehensive and easy-to-use reflects the Taylor Hobson expertise at putting metrology to work in support of manufacturing.

## Total system control

µltra takes charge of all functions to eliminate hardware / software conflicts typically created by third party or after market software packages. Mechanical performance is optimized by use of patented software routines and proprietary calibration techniques.

- Mechanical functions - positioning and speed of all axis movements
- Administrative functions - user preferences, data storage and retrieval
- Analysis functions - application of filters and constants, calculation of results
- Display functions - screen graphics, customized templates, print commands

## Compatibility

µltra was designed to be fully compatible with older Taylor Hobson data file formats, thus enabling re-analysis and comparison of old data. It also has a programmable facility for the simple export of results to standard packages such as SPC and Excel™.

## Compliance with international standards

Whatever the parameter and wherever in the world it happens to be measured it is guaranteed to be correct. µltra also adheres to industrial metrology disciplines as practiced by leading manufacturers around the globe.

- Calibration routines are easily integrated into corporate ISO 9001 procedures
- Artifacts used for calibration can be identified and referenced to certification date
- Calibration history regarding operator, artifact and date is automatically stored
- Separate calibrations for different probe arms can be saved and easily restored

## Industrial strength interface

Although written with familiar Windows conventions, µltra has the look and feel of a machine tool interface. Commands are direct, purposeful and driven by intuitive logic. Perhaps for the first time in metrology the computer is a bridge instead of a barrier between operator and instrument.



µltra powers Form Talysurf Series surface roughness measuring systems



µltra powers Talyrond roundness and cylindricity measuring systems



µltra simplifies training and eliminates the need for dedicated, single system operators

## Multi-instrument architecture

ultra takes full advantage of client/server technology and is designed to drive all Taylor Hobson hardware devices including Form Talysurf Series instruments and Talyrond roundness systems.

- Operators familiar with ultra can easily operate multiple instruments
- No need for dedicated, single instrument operators
- Transfer of knowledge is simplified when operators are promoted or transferred
- Network ready for central data storage and output to network printers

## Comprehensive analysis

ultra includes as standard everything important to the measurement of circular geometry. All the basic roundness parameters are here along with advanced analysis tools that are either unavailable or available only at extra cost from other suppliers.

- Asperity removal
- Coaxiality
- Cylindricity
- DFTC / DFTP
- Harmonic analysis
- Hole and edge removal
- Slope

## Computer aided center and leveling

Any operator can center and level a component quickly and correctly just by following a few screen prompts. During the process a dynamic on-screen display shows the operator the exact position of the gauge head. With practice, high speed is possible. With ultra, accuracy is guaranteed.

## Programmable measuring routines

Whether in semi-automatic, manual or automatic mode, the entire measuring sequence can be programmed. This ensures that every step is performed in the right sequence and that filters, parameters and evaluation methods are always identical.



cylindricity analysis with Talyrond 131



computer assisted center and leveling powered by ultra software

# µltra Roundness software - at work on a typical component

To illustrate the effectiveness with which µltra can achieve the highest possible accuracy, a series of measurements will be performed on a typical manufactured component.



## Roundness on continuous surface

The first procedure will be a basic centering and leveling routine made on the surface indicated in red. Centering and leveling repositions the table to mechanically align the axis of the component with the axis of the spindle. This serves to prevent the inclusion of fixturing errors in the roundness analysis.



before centering



after centering

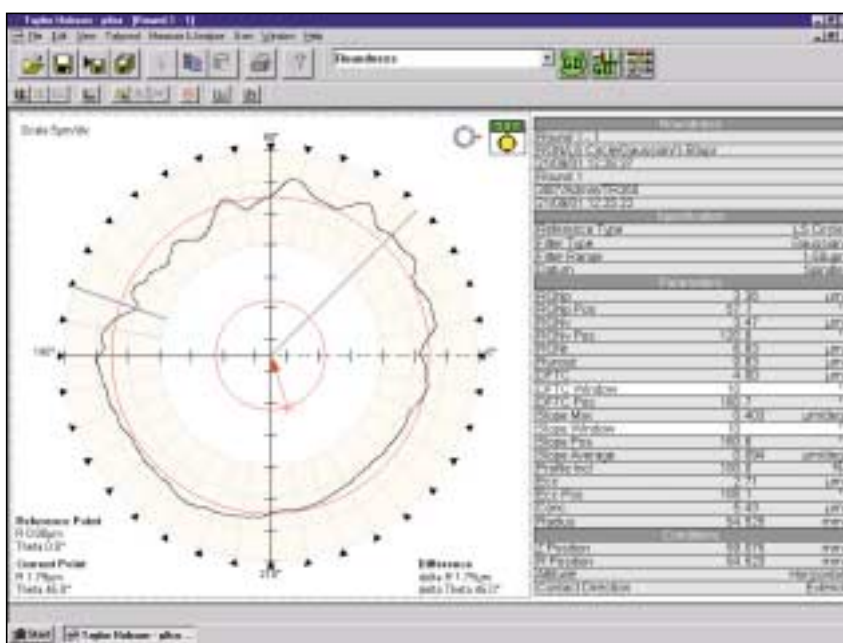
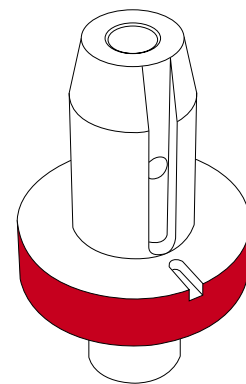

measurement results

After centering and leveling is complete a fresh measurement is taken and the roundness results are displayed in both tabular and graphical format. µltra provides a full and accurate assessment of roundness with respect to any of the four internationally recognized reference circles:

- Least Squares Circle
- Minimum Zone Reference Circle
- Minimum Circumscribed Circle
- Maximum Inscribed Circle

## Measurements on interrupted surfaces

Interruptions and asperities will have a detrimental influence on measurement results if they are not excluded from the analysis. *ultra* can automatically or manually exclude data caused by intended or unintended interruptions.

## Cylindricity / Coaxiality / Concentricity

Cylindricity is a powerful tool that combines data from multiple roundness profiles into a single geometric figure. For this example four profiles will be measured on the surface indicated in blue. Note that the keyway has been automatically excluded from analysis.

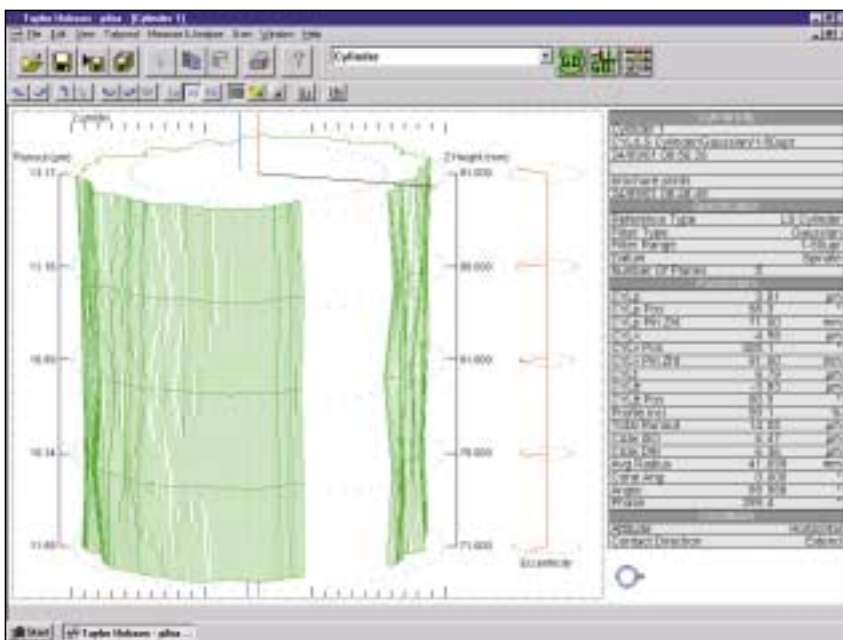
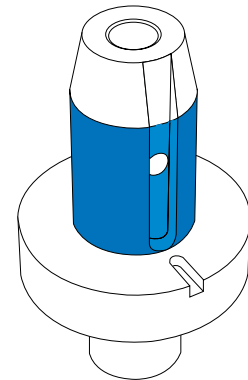

cylindricity results (Talyrond 131 only)

*ultra* provides a full and accurate assessment of cylindricity with respect to any of the four internationally recognized reference systems:

- Least Squares Cylinder
- Minimum Zone Reference Cylinder
- Minimum Circumscribed Cylinder
- Maximum Inscribed Cylinder

In addition, the axis calculated from the cylinder analysis can be used as a reference datum and compared with another axis for the assessment of coaxiality, concentricity, run-out and total run-out.

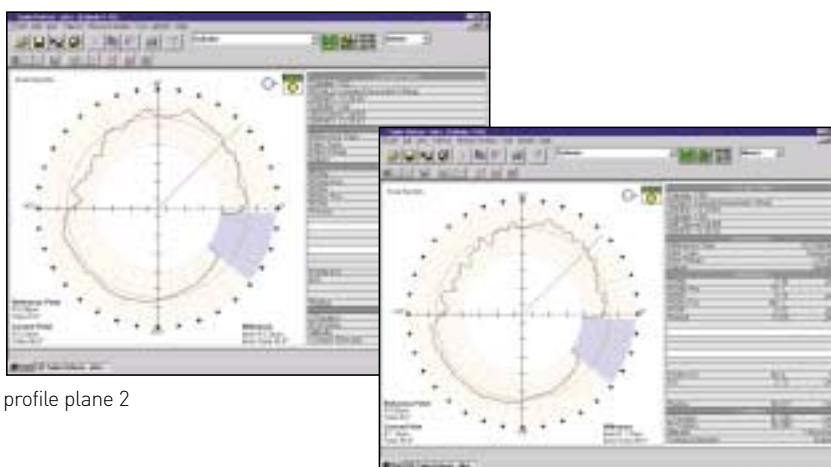

profile plane 2

profile plane 4

Individual planes can be extracted from the cylinder for additional analysis. In this case the roundness values for planes 2 and 4 are displayed.

Note, the blue shaded area indicates data excluded from the measurement results.

# Accessories

All the accessories you need to begin using Talyrond 131 and 130 are supplied as standard. However, for more demanding measuring requirements, we have a range of accessories which may be ordered separately.

## ❶ Large Computer Desk

1260mm wide x 850mm deep x 750mm high (49.6" x 33.5" x 29.5"). Locking cabinet can be assembled to left or right of the desk.

**code 112-2998-01** Optional

## ❷ Storage Unit

820mm wide x 625mm deep x 640mm high (32.3" x 24.6" x 25.2"). Designed to fit under the small computer desk. Features lockable doors and is mounted on castors for easy installation.

**code 112-3142-01** Optional

## ❸ Small Computer Desk

900mm wide x 850mm deep x 750mm high (35.5" x 33.5" x 29.5"). A small drawer is provided for tools, styli, etc.

**code 112-3144-01** Optional

## Monitor Support

Monitor support with vertical and swivel adjustment.

**code 112-3182** Optional

## ❹ Centering Attachment -

For repeatable centering of small components capacity up to 105mm (4in) diameter.

**code 155/P25730** Optional

## ❺ Six jaw component chuck -

A 6 jaw precision scroll chuck. Capacity - Inside diameter 20mm - 95mm (0.78in - 3.74in). Capacity - Outside diameter 2mm - 32mm (0.08in - 1.26in).

**code 112/1859** Optional

## ❻ Stylus Arms

Ruby ball x 100mm (3.94")

**1mm** (0.039in) diameter,

**code 112/2253** Optional

**2mm** (0.078in) diameter,

**code 112/2254** Standard

**4mm** (0.157in) diameter,

**code 112/2255** Optional

**Bar Stylus** - A 100mm (3.9in) stylus for measuring small diameter components.

**code 112/2256** Optional

**Measuring Gauge** - Talymin single bias inductive gauge with 2mm (0.078") range.

**code 112/1855** Standard

## Stylus stop attachment -

For limiting movement of the stylus when measuring interrupted surfaces.

**code K501/1547** Optional

## Kinematic Dowel Support Set -

For stable workpiece mounting.

**code 112/1861** Optional

## "Lets Talk Roundness" book

A 64 page handbook on the theory and practice of roundness measurement.

**code 600-5** Standard



## 7 Glass hemisphere

- for checking overall system performance. UKAS calibration certificate is optional.

Roundness < 0.05µm (2µ")  
code 112/436 Optional

## 8 Calibration set -

For calibrating the gauge head. Comprises a circular glass flat and three gauge blocks (2.5mm, 2.8mm and 3mm). UKAS calibration certificate is optional.  
code 112/1874 Optional

## 9 Precision test cylinder -

for checking the instrument's vertical straightness accuracy and the parallelism of the vertical axis to the spindle axis. UKAS calibration certificate is optional.

300mm (11.8") cylinder  
Roundness < 0.25µm (10µ")  
Straightness < 0.5µm (20µ")\*  
code 112/1888 Optional

\*Straightness over central 90% of cylinder length

## 10 Cresting standard -

For checking the vertical and horizontal alignment of the gauge head.

code 112/1876 Optional

## Reservoir assembly kit -

If the air supply is of poor quality or unreliable and does not meet the instrument's standards, then the reservoir assembly is recommended to provide an even flow of air to the spindle.

code 112/2869 Optional

## 11 Stylus Kit -

For assembling stylus arms for use with work pieces where the standard styli are unsuitable.

code 112/2235 Optional

## 12 Flick standard -

for rapid calibration of gauge head sensitivity; alternative to the gauge calibration set.

20µm (788µ") range  
code 112/2308 Optional

300µm (.012") range  
code 112/2233 Optional

**Instrument Cover** - To protect the instrument when not in use.  
code 112/1393 Optional

**Fuse and Bulb Kit**  
code 112/2131 Standard

**Pre-Filter Element**  
code 112/2859 Optional

**Accessory case** - A useful case for carrying standard and optional accessories.  
code 48/453 Optional

**Set of hexagonal wrench keys** - To assist with minor adjustments on the instrument.  
code 630/412 Optional

**Coalescing filter element** - Secondary filter to be changed every three months to maintain a clear air supply, (1 included with the instrument).  
code 112/2858 Optional

## Special Requests

Taylor Hobson can also provide customized products which are designed to exactly match your requirements. These include work holding devices for components with specific dimensions and special styli for applications such as small bores, shoulders or undercuts.



# Choosing the right product

## Talyrond 131

### Cost effective cylindricity

#### Motorized for automatic measuring

Talyrond 131 systems incorporate a motorized column and radial arm for automatic measuring runs. Programmed routines shorten cycle times and minimize operator influence on results. The built in vertical reference unit extends capability to include cylindricity and total run out.

- Capacity for large components
- Functional, low maintenance construction
- Equally at home in the inspection room or on the production floor
- Simple to set up and operate
- Integrated electronic interface module

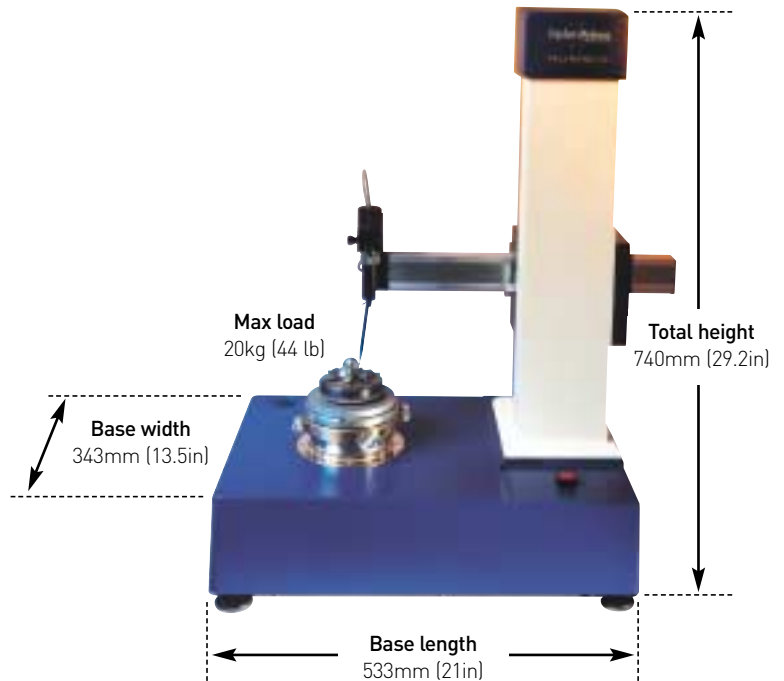

## Talyrond 130

### Affordable and accurate roundness

#### Precise manual positioning

The Talyrond 130 is equipped with positive friction positioning controls on the column and the arm. This direct drive response to movement of the large, ergonomic hand wheels feels precise and is precise. Drift, backlash and slop are greatly reduced without the need for clumsy, inefficient clamping devices.

- Interactive programming with operator prompts
- Rugged, compact construction for use anywhere in the plant
- Engraved scales for accurate positioning
- Self contained electronic interface module,  
Length = 250mm (10in)  
Width = 160mm (6.3in)  
Height = 80mm (3.2in)

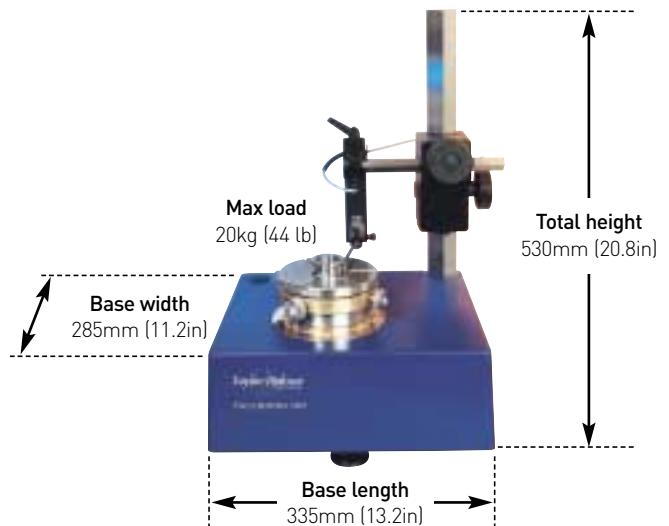

**Note:** To allow for supply fluctuations, the preferred air pressure is 80-120lb/in<sup>2</sup> [5.4 to 8.1 bar] however where a constant supply pressure can be maintained, a minimum air pressure of 50lb/in<sup>2</sup> [3.4bar] is acceptable. Talyrond 130 and 131 instruments conform to all applicable requirements of BS EN 50081-2 (1994) and BS EN 50082-1 (1998) and comply with the requirements of the EMC Directive 89/336/EEC.

Roundness, concentricity, eccentricity and run out measurements can be made with reference to Least Squares Circle, Minimum Zone Circle, Maximum Inscribed Circle or Minimum Circumscribed Circle, flatness and squareness to Least Squares and Minimum Zone

# Specification

		Talyrond 130	Talyrond 131
<b>Measuring Capacity</b>	Max diameter	200mm (8in)	370mm (15in)
	Max height	200mm (8in)	225mm (9in)
	Max weight (balanced load)	20kg (44lb)	20kg (44lb)
<b>Weights and Dimensions</b>	Main instrument: overall weight	38kg (85lb)	62kg (136lb)
	Overall length (arm fully retracted)	455mm (17.9in)	820mm (32in)
	Overall width	285mm (11.2in)	343mm (13.5in)
	Overall height	530mm (20.8in)	740mm (29.2in)
<b>Cylindricity Reference Unit</b>	Straightness error*	-	< 3µm/225mm (118µin/8.8in)
	Parallelism (in the measuring plane)*	-	< 3µm/225mm (118µin/8.8in)
	Positional control uncertainty	-	+/- 250µm (0.01in)
	*Note: Straightness/parallelism specification based on calculations from a series of radial traces using an LS circle		
<b>Worktable &amp; Spindle</b>	Worktable diameter	125mm (4.94in)	
	Range of manual centering	+/- 1.25mm (±0.054in)	
	Range of manual leveling	+/- 30 arc minutes	
	Height of neutral plane	51mm (2in)	
	Speed of rotation	6rpm clockwise nominal	
	System roundness limit of error**	+/- (0.025µm +0.00025µm/mm) +/- (0.98µin+0.25µin/in)	
	Axial limit of error	0.025µm (0.98µin)	
	**Note: Departure from the least squares circle at 6rpm with 1-50µm filter (departure may be inward or outward)		
<b>Gauge Range &amp; Resolution</b>	Maximum range	+/- 1mm (+/- 0.039in)	
	Resolution at maximum range	0.03µm (1.18µin)	
	Minimum range	+/- 0.2mm (+/- 0.008in)	
	Resolution at min range	0.006µm (0.24µin)	
<b>Filter Options</b>	Phase corrected 2CR, gaussian and bandpass filtering available by menu selection. Filtering is operator selectable from 1-15µm, 1-50µm, 1-150µm, 1-500µm, 15-150µm, 15-500µm and user selected.		
<b>Electrical Supply -</b>	<b>Alternating supply, single phase with earth (3 wire system)</b>		
	Voltage	90-260v	
	Frequency	47-63Hz	
	Consumption (total system)	250VA max, 160w	
<b>Environmental Conditions</b>	Temperature:	Operating 10-35°C (50°F - 95°F)	
	Storage	-10 to +50°C (14°F - 122°F)	
	Temp/time gradient	less than 2°C / hour (3.6°F / hour)	
	Humidity Operating	30% to 80% relative, non-condensing	
	Storage	10% to 90% relative, non-condensing	
	Free air flow rate	1.0m / sec maximum steady (39.4in / sec)	
<b>Air Source Requirements</b>	Maximum source pressure	8.1bar (120psi)	
	Minimum source pressure	5.4bar (80psi)	
	Air consumption	0.037cu.m / min (1.3scfm)	
	Operating pressure	4.1bar (60psi)	
	Filtering	5µm (200µin)	
	Moisture content - dewpoint	2°C (3.6°F)	
<p>All accuracies and uncertainties are quoted at 20°C ±1°C (68°F ± 1.8°F). NOTE: Taylor Hobson pursues a policy of continual improvement due to technical developments. We therefore reserve the right to deviate from catalog specifications.</p>			

At Taylor Hobson we don't sell products - we provide solutions. Whatever our customers' measuring needs, we will find a solution to meet them.

Our reputation for excellence is based on more than 100 years of metrology design and manufacturing experience. Add to this our worldwide coverage, our after sales support and our commitment to customer care and you have a company which provides its customers with total peace of mind.

### The Taylor Hobson service:

#### Special applications

We have a team of engineers who provide a design service for dedicated metrology solutions. This can involve customising standard Taylor Hobson instruments to meet specific requirements or designing unique products.

For details of your local support center phone **+44 116 246 3034** or e-mail [sales@taylor-hobson.com](mailto:sales@taylor-hobson.com)

#### Centers of Excellence

Our Centers of Excellence, offer:

- product and theory training either at our local training centers or at our customers' premises
- instrument and metrology advice
- a trial measurement service to help you decide which product to buy
- lectures and presentations

For details of your local Center of Excellence phone **+44 116 276 3779** or email [cofe@taylor-hobson.com](mailto:cofe@taylor-hobson.com)

#### After sales support

To ensure that all our products are maintained to the standards you require, we offer a range of after sales service packages. They include an on-site calibration service, field service and a refit and upgrade service.

We also offer an instrument calibration service at our UKAS laboratory in Leicester.

For details of your local support center phone **+44 116 246 3135** or email [service@taylor-hobson.com](mailto:service@taylor-hobson.com)

### Taylor Hobson SA

6 avenue de Norvège, Hightec 4  
91953 Courtaboeuf Cedex, France  
Tel: +33 160 92 14 14 Fax: +33 160 92 10 20  
e-mail: [contact@taylor-hobson.fr](mailto:contact@taylor-hobson.fr)



### Taylor Hobson GmbH

Postfach 4827, Kreuzberger Ring 6  
65205 Wiesbaden, Germany  
Tel: +49 611 973040 Fax: +49 611 97304600  
e-mail: [info@taylor-hobson.de](mailto:info@taylor-hobson.de)



### Taylor Hobson S.p.A.

S.p. 28 Vigentina 6,  
20090 Opera, Milan, Italy  
Tel: +39 0257 606424 Fax: +39 0257 606740  
e-mail: [taylor.hobson@libero.it](mailto:taylor.hobson@libero.it)



### Taylor Hobson Liaison Office

Austria and Eastern Europe  
Amalienstrasse 68, A-1130 Vienna, Austria  
Tel: +43 1877 557112 Fax: +43 1877 557116  
e-mail: [thp@vienna.at](mailto:thp@vienna.at)



### Taylor Hobson KK

No 31 Kowa Building 19-1, 3-Chome, Shiroganedai  
Minato-Ku, Tokyo 108-0071, Japan  
Tel: +81 33473 7001 Fax: +81 33473 7002  
e-mail: [mail-box@taylor-hobson.co.jp](mailto:mail-box@taylor-hobson.co.jp)



### Taylor Hobson K INC

Hungkuk Life Building, 5<sup>th</sup> Floor 6-7, Soonae Dong  
Pundang-Ku, Seongnam, Kyungki-Do, 463-020, Korea  
Tel: +82 31 713 1371 Fax: +82 31 713 1372  
e-mail: [thkorea@kornet.net](mailto:thkorea@kornet.net)



### Taylor Hobson China Office

20/F, Delta House, 3 On Yiu Street  
Shatin, New Territories, Hong Kong  
Tel: +852 2757 3033 Fax: +852 2757 1767  
e-mail: [talhobhk@netvigator.com](mailto:talhobhk@netvigator.com)



### Taylor Hobson Inc

Suite 350, 2100 Golf Road, Rolling Meadows,  
Illinois 60008-4231, USA.  
Tel: +1 847 290 8090 Fax: +1 847 290 1430  
e-mail: [taylorhobson@csi.com](mailto:taylorhobson@csi.com)



### Taylor Hobson Limited

PO Box 36, 2 New Star Road, Leicester, LE4 9JQ, England.  
Tel: +44 116 276 3771 Fax: +44 116 246 0579  
e-mail: [sales@taylor-hobson.com](mailto:sales@taylor-hobson.com)  
Internet: <http://www.taylor-hobson.com>

